



# TOWBAR INSTALLATION INSTRUCTIONS

PART NUMBER 03406RW

TOYOTA LANDCRUISER PRADO 150 CL4



## PRODUCT DETAILS:

Part Number:	03406RW	Maximum Towing Braked:	3000	kg
ECU Number:	04826	Maximum Towing Unbraked:	750	kg
Tail Harness Length Required:	1200mm	Maximum Static Ball Load:	300	kg
TBM/Lug Part Number:	21161			
Wiring Part Number:	100210-WL			

## FITTING DETAILS:

Towbar Installation Time:	60 Mins.	Hayman Reese SmartCODE Solution Required:	NO
Wiring Installation Time:	30 Mins.	RPA Disable/Other:	NO
Total Installation Time:	90 Mins.		
Bumper Cut Required:	No		



# TOWBAR INSTALLATION INSTRUCTIONS

PART NUMBER 03406RW

TOYOTA LANDCRUISER PRADO 150 CL4

ENSURE THAT INSTRUCTIONS ARE UNDERSTOOD PRIOR TO FITMENT.

## **i** BEFORE YOU START:

Hayman Reese recommends that instructions are read completely prior to fitment. Check all hardware items have been included refer to assembly diagram. Please ensure this towbar is only fitted to vehicle models as per Hayman Reese application guide ([www.haymanreese.com.au](http://www.haymanreese.com.au)).

### Bumper Cuts



Vehicle and bumper variations can and do occur during vehicle manufacture after initial towbar design. Fitment of towbar to vehicle and accuracy of bumper cut must be assessed prior to any bumper modifications made. Incorrect bumper cuts are not covered under Hayman Reese warranty.

**NOTE: Bumper cuts need to be approached with care, refer to notes below.**

- Bumper centreline – where the centreline of the bumper needs to be determined, the installer must assess centre point by measurement of bumper width or determining two symmetrical reference points to give centreline.
- Bumper edge – To assist with accurate bumper cut measurement, reference to the start of the bumper edge is now being commonly used.
  - Measure from bottom edge along bumper and around corner to the 70 mm point (Figure 1).
  - Do not measure from visible bumper front of corner, upwards (Figure 2).

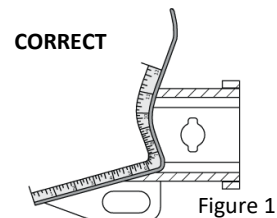

Figure 1

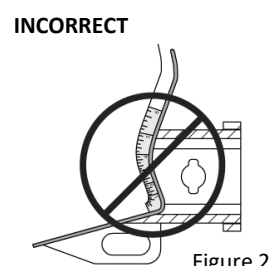

Figure 2

### Drilling

- For any required drilling during installation, ensure that the area is clear of fuel, electrical & other components that may be damaged.
- All holes drilled into the body panels shall have all burrs & swarf removed then coated with a suitable rust preventative paint.

### Bolts/Fasteners

- Ensure that all hardware is fastened to correct torque as specified in this fitting instruction.
- All fasteners supplied with this product are used to achieve a specified clamp loading. If replacement is required ensure that fasteners of the same grade and class are used.



**NOTE: Achieving correct torque is critical to proper installation and responsibility of the installer. Towbar failures attributed to tension issues from over tightening or under tightening are not covered by Hayman Reese warranty.**

### Product Labels

- a. Towbar load rating sticker provided with this product shall be conspicuously located on inside rear end of the driver's door.
- b. Powertrain Control Module (PCM)/Body Control Module (BCM) upgrade warning label will be provided in towbar kit for vehicles as required. Affix warning label in door and owner's handbook.

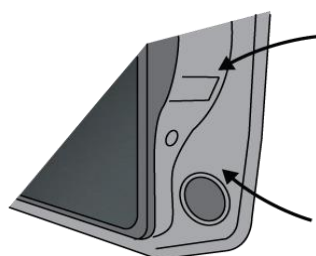

Place **Load Rating sticker** inside driver's door here

Place **Vehicle PCM/ BCM upgrade warning label** in door AND on front cover of owner's service handbook

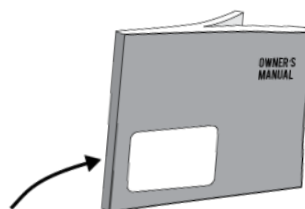

## WARNING:

**Do not, drill, cut, weld or otherwise modify the towbar.**

**FOR TOWING PURPOSES ONLY - This towbar is designed and tested by Hayman Reese to adhere to ADR 62/02 which provides only for the expected load demands of towing.**



# TOWBAR INSTALLATION INSTRUCTIONS

PART NUMBER 03406RW

TOYOTA LANDCRUISER PRADO 150 CL4

## **i** TOWBAR ASSEMBLY DIAGRAM

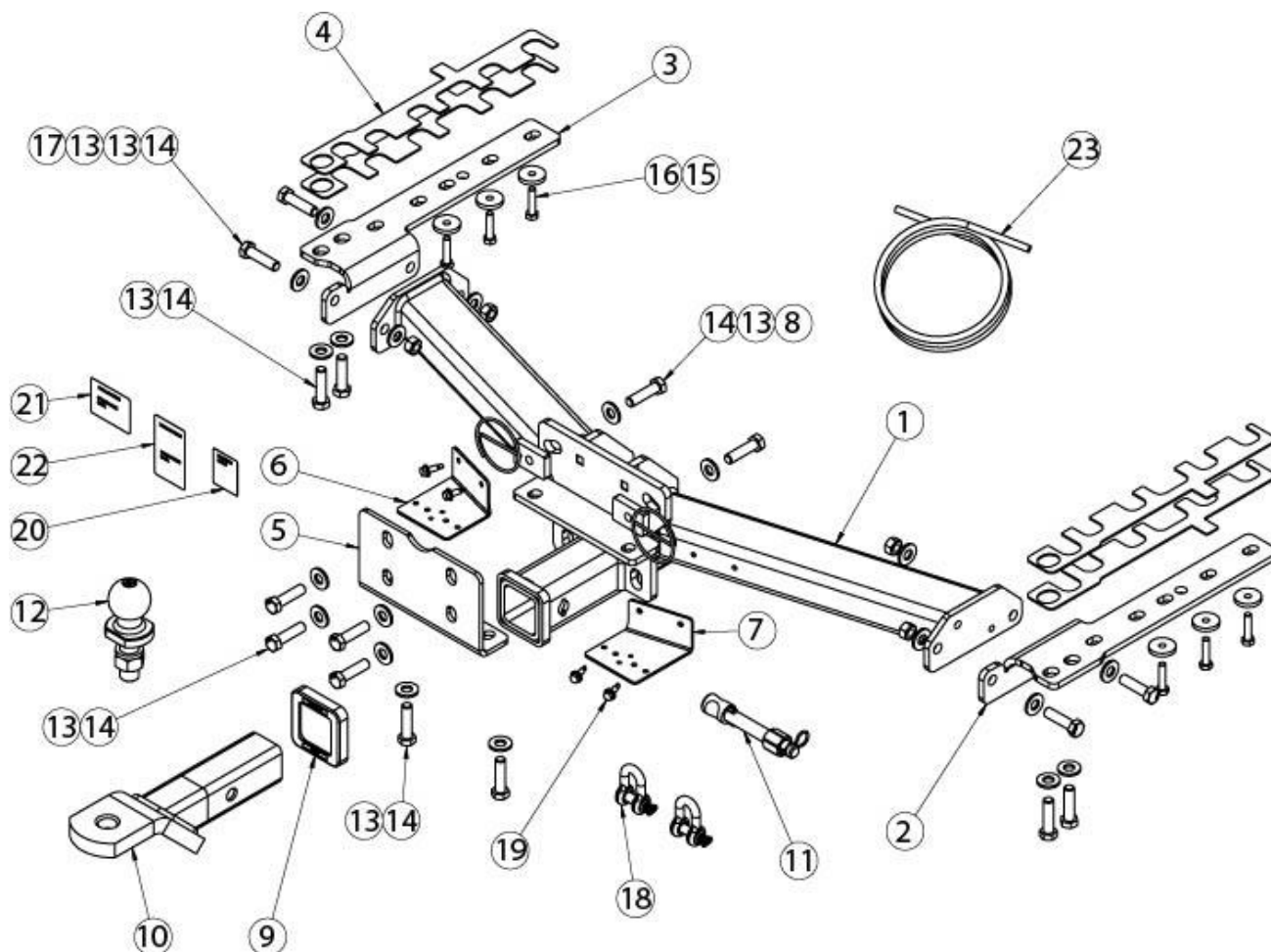

ITEM	DESCRIPTION	QTY
1	PRADO 150 WELDED ASSY	1
2	SIDE ARM RHS	2
3	SIDE ARM LHS	1
4	SPACER PLATE	4
5	CLAMPING PLATE	1
6	PRADO 150 PLUG BRACKET, LH	1
7	PRADO 150 PLUG BRACKET, RH	1
8	M12x1.25P TAP PLATE WITH 300 WIRE	2
9	HITCH BOX COLLAR COVER	1
10	TRAILER BALL MOUNT	1
11	SMART PIN GOLD	1
12	TOWBALL 50mm	1

ITEM	DESCRIPTION	QTY
13	WASHER PLAIN 1/2"	20
14	SET SCREW HEX HD M12x45x1.25P	16
15	WASHER PLAIN 8x32x5mm	6
16	BOLT HEX HD M8x35x1.25P	6
17	NUT HEX HD M12x1.25P	4
18	"D" SHACKLE 10mm	2
19	TEK SCREW 14-20 HEX HD 22mm	4
20	HAYMAN REESE LOGO STICKER	1
21	COMPLIANCE LABEL	1
22	LOAD RATING LABEL	1
23	WIRING LOOM	1

1. Release the tailgate to expose the rear cabin.
2. On the LH side, remove 2 x scrivenets located around boot opening.

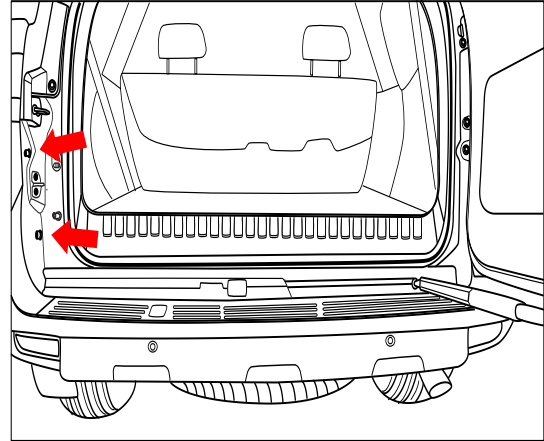

3. Using a trim removal tool, carefully extract the rear garnish from the top of the bumper.

To assist locating the clips. Measured from the left side edge of the step trim, the clip position are at these approximate positions: 60mm, 210mm, 350mm, 480mm, 800mm, 935mm, 1080mm and 1180mm

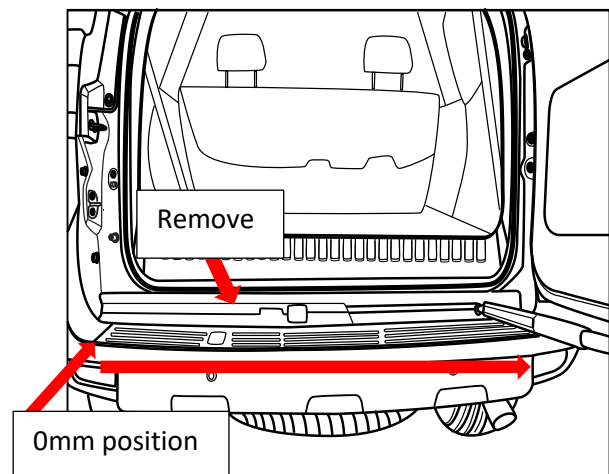

4. With the bumper fully exposed, remove 5 x set screws located behind the removed rear garnish.

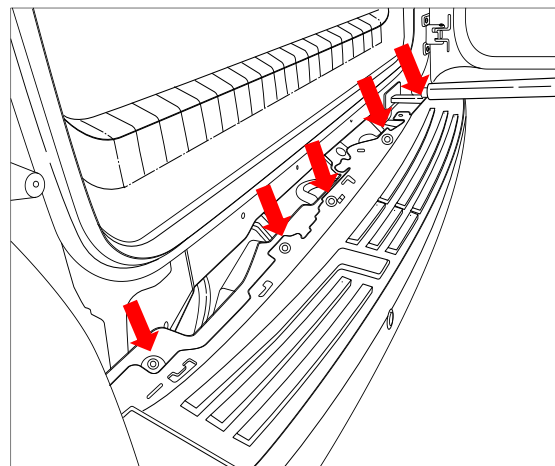



# TOWBAR INSTALLATION INSTRUCTIONS

PART NUMBER 03406RW

TOYOTA LANDCRUISER PRADO 150 CL4

5. On the inside of the wheel arch, remove 1 x screw and 2 x scrivenets.

Repeat for the other side.

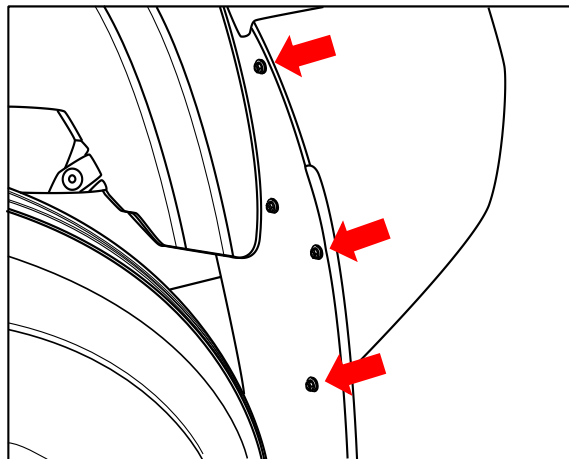

6. Underneath vehicle on the LH side, remove 3 x screws.

Repeat for the other side.

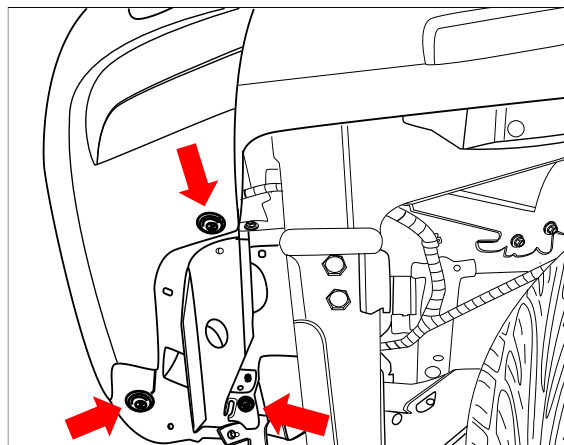

7. Remove 2 x screws from the rear bumper tabs.

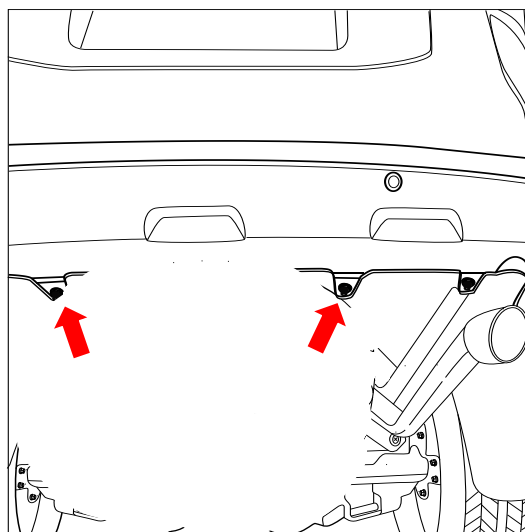



# TOWBAR INSTALLATION INSTRUCTIONS

PART NUMBER 03406RW

TOYOTA LANDCRUISER PRADO 150 CL4

- Carefully unclip the bumper assembly from vehicle and set aside. Ensure to disconnect wiring harness connector and sensors connector located on the passenger and drivers side.

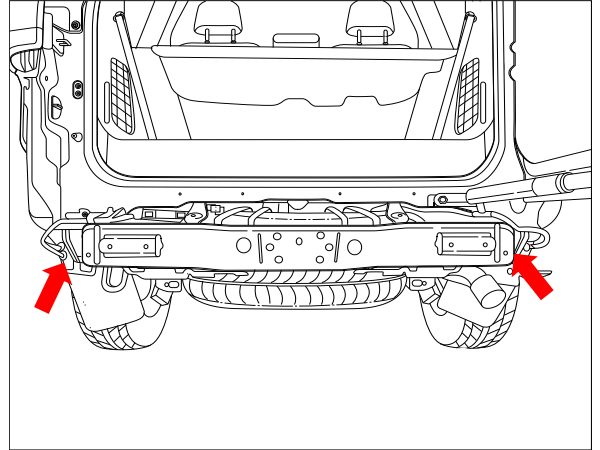

- On the passenger side remove and discard the factory shipping hook secured with 2 x bolts.

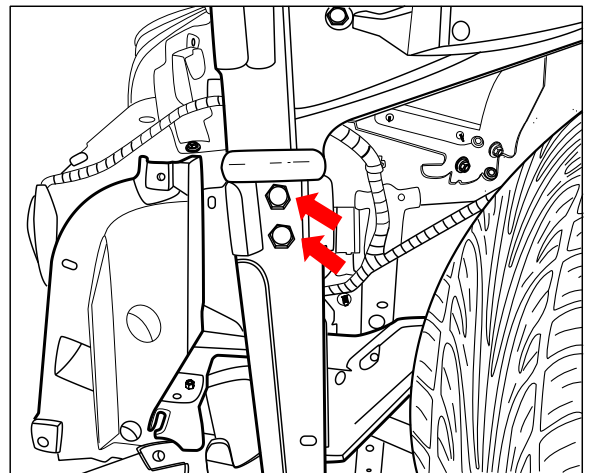

- Remove 4 x bolts securing fuel protector from underside of vehicle as shown and discard bolts.

Fuel protector will remain supported by a 5<sup>th</sup> bolt towards the front of vehicle. Leave this bolt and provide additional support if required.

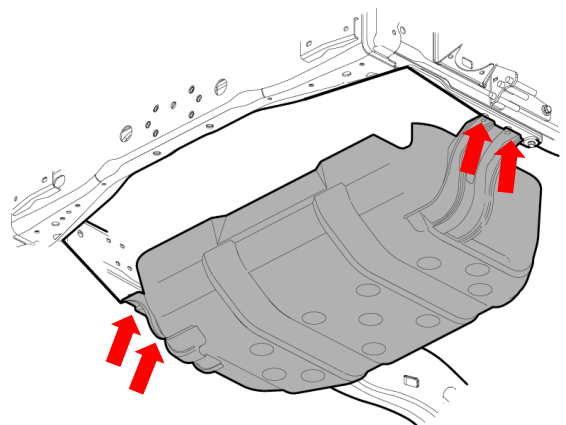

11. Note the hole variation on the side arms for the specific vehicle prior to the next step.

5-Door Variants:

3-Door Variants:

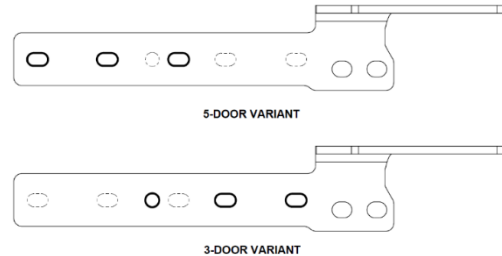

12. Loosely secure the LH Sidearm to chassis rail (2<sup>nd</sup> last mounting point) with 1 x M12 x 45mm bolt complete with 1 x washer and to the most forward position (vehicle specific) with 1 x M8 x 35mm bolt complete with 1 x washer.

Repeat for other side.

Use supplied spacer plates as required to ensure holes align to crosstube assy (refer to step 17). To install spacer plate, slide in the spacer between the side arm and bottom of chassis rail.

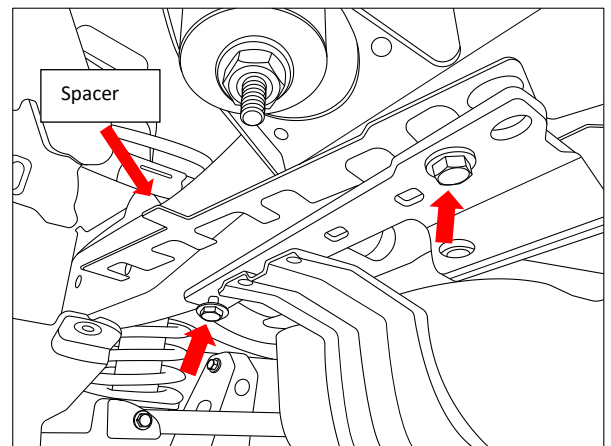

13. Fit the plug brackets to the crosstube with 2 x tek screws per bracket.

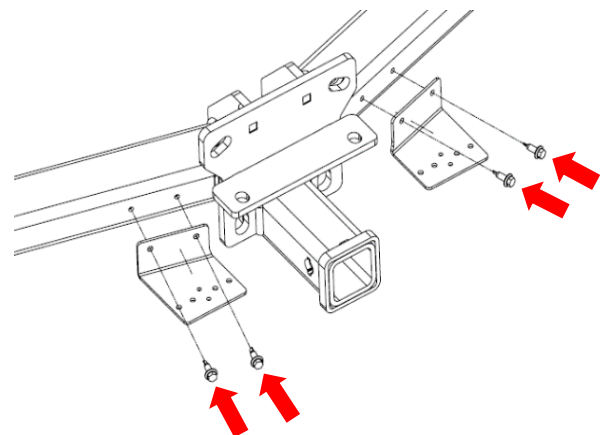

14. Lift the crosstube up to the side arms and loosely secure each side with 2 x M12 bolts complete with 2 x washers and 1 x nut per bolt.  
(You could temporarily support the centre section with an M12 bolt to assist with this step)

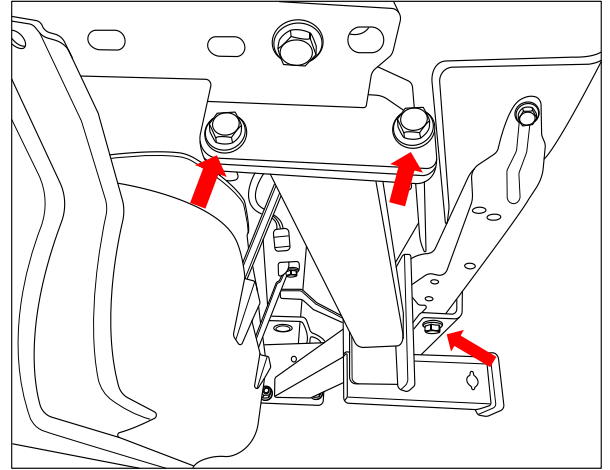

15. Insert 2 x tapped plate on wire into the chassis rail and loosely secure the crosstube to the rear side of vehicle chassis with 2 x M12x45mm bolts along with 1 x washer and 1 x tapped plate per bolt.

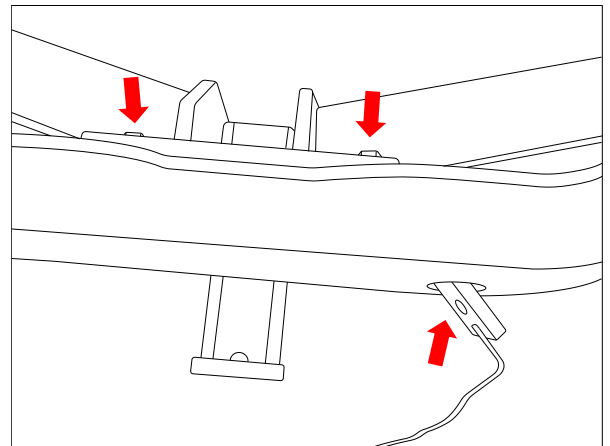

16. Loosely secure the clamping plate along with the crosstube to the chassis rail with 6 x M12 bolts complete with 1 x washer per bolt.  
Ensure that the bottom bolts are relatively secure at this stage to determine if spacer plates are required for step 17.

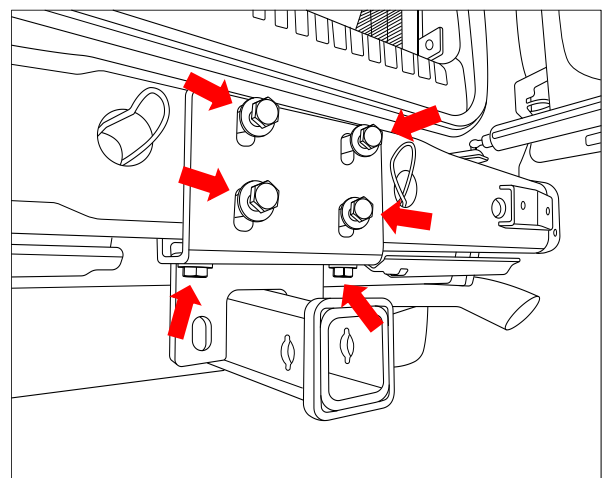



# TOWBAR INSTALLATION INSTRUCTIONS

PART NUMBER 03406RW

TOYOTA LANDCRUISER PRADO 150 CL4

17. Insert the spacer plates between the side arm and chassis rail if required (refer step 11). Complete the side arm mounting along with the fuel tank protector to the chassis rail with 2 x M8 x 35mm bolts complete with 1 x washer per bolt and the rear most position with 1 x M12 bolt complete with 1 x washer per bolt.

Repeat for other side.

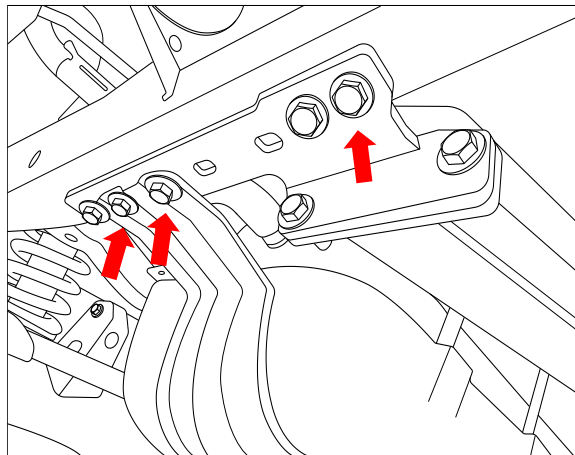

18. Starting with the crosstube centre bolts, torque all bolts to the torques listed below:

**M12 : 125 N.m**

**M8 : 22 N.m**



# TOWBAR INSTALLATION INSTRUCTIONS

PART NUMBER 03406RW

TOYOTA LANDCRUISER PRADO 150 CL4

## IMPORTANT

Due to possible vehicle variations, always confirm any noted vehicle colour wires with a multi-meter to ensure the correct function is identified before soldering or scotch locking. For vehicle wires denoted with two colours (example; RED/GREEN) the first colour will always be the main wire colour while the second colour is the thinner trace colour on the wire.

19. In the luggage compartment, remove the rear trim (1) from the vehicle.

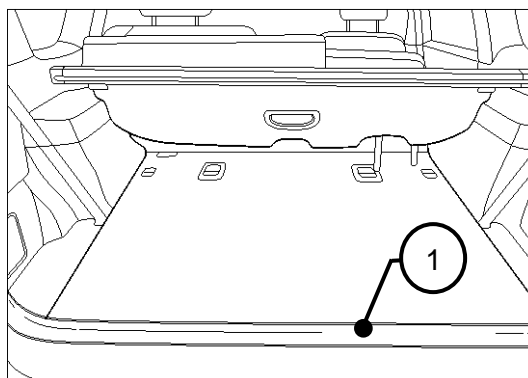

20. Remove the lower access panel (1). Remove the LHS luggage compartment trim clip (2) this will allow for dislodging the trim to access the rear quarter area.

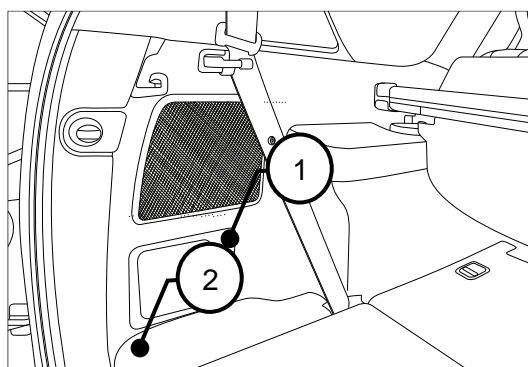



# TOWBAR INSTALLATION INSTRUCTIONS

PART NUMBER 03406RW

TOYOTA LANDCRUISER PRADO 150 CL4

21. Connect the Trailer Patch Harness (P/No: 100210-WL) (1) to the vehicle breakout connector (2).

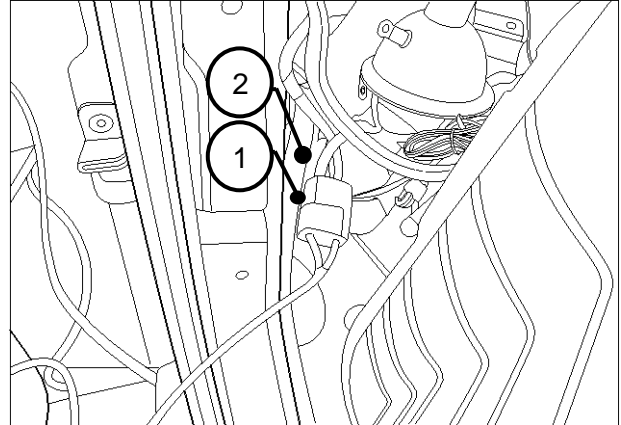

22. Connect the Trailer Patch Harness (1) to the ECU module (2). Adhere the ECU module (2) to the indicated location in the cavity below the LHS tail light. **Ensure the ECU is mounted with the connector facing downwards.**

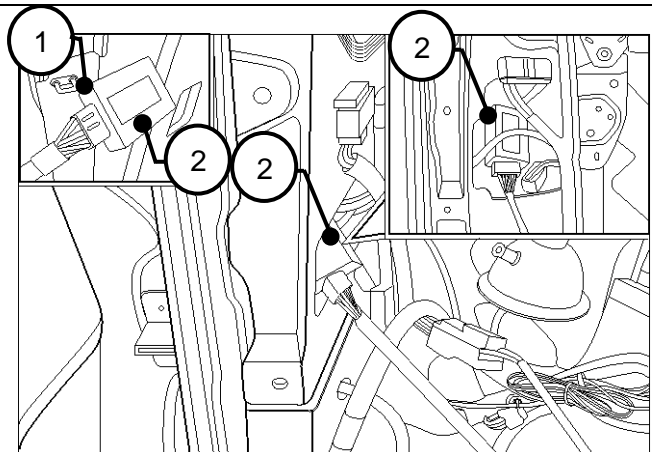

23. Secure the earth ring terminal to the earthing point (1).

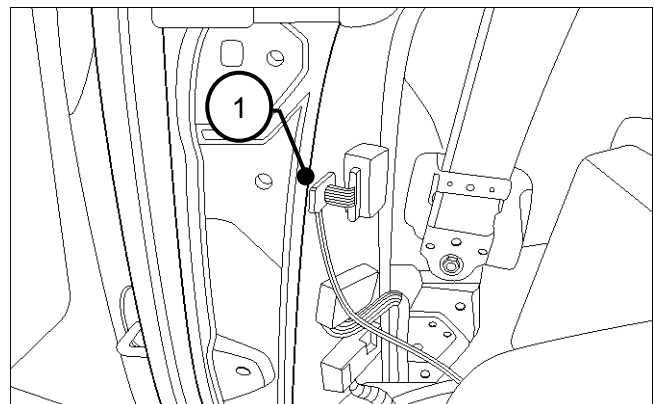

24. On the exterior LHS rear quarter area above the vent, drill the smaller existing vehicle grommet out to  $\varnothing 30\text{mm}$  hole in the indicated location (1). File back any rough edges and apply rust inhibitor.

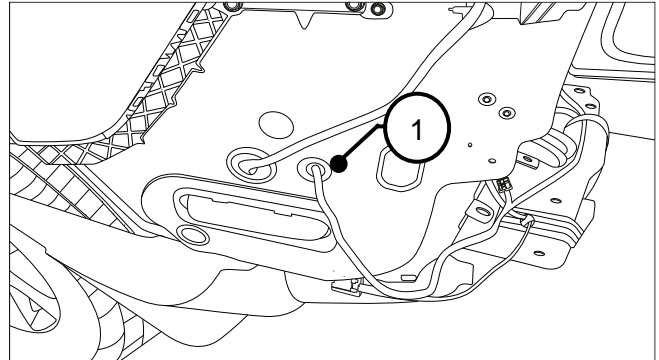

25. Secure the Tail Harness (Tail length 1200mm) trailer socket (1) to the towbar mounting bracket using M4 fasteners.
26. Route the Tail Harness over to the previously drilled hole and feed the connector into the vehicle.
- Route to the exterior LHS grommet.**
27. Adjust the harness grommet to the required position and secure grommet with a cable tie and then secure the grommet in place.
28. Secure the harness to the towbar using cable ties.

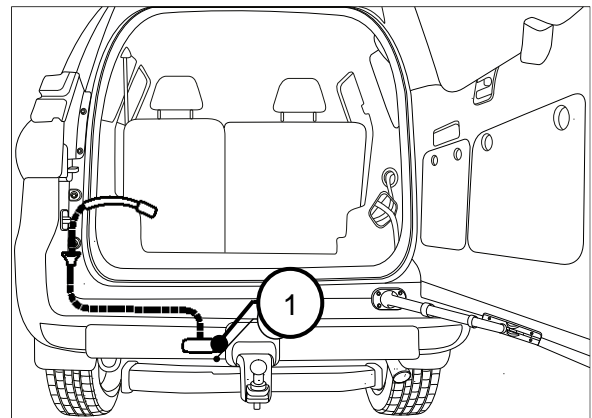

29. Connect the tail harness 8-way connector (1) to the trailer patch 8-way mating connector (2).

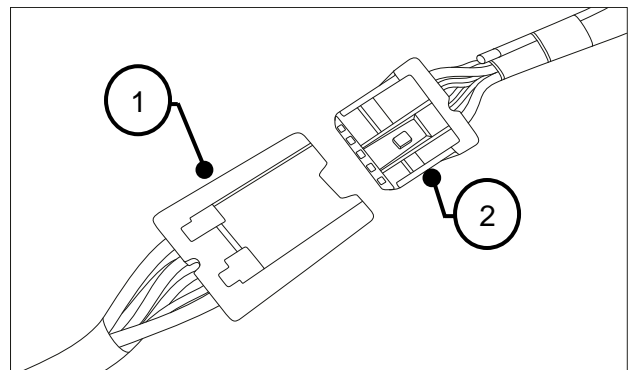



# TOWBAR INSTALLATION INSTRUCTIONS

PART NUMBER 03406RW

TOYOTA LANDCRUISER PRADO 150 CL4

---

30. Test the body harness using a light board or multimeter.
  31. Secure all harnesses using cable ties (not supplied).
  32. Re-fit all removed parts and secure all fasteners, ensuring there are no squeaks or rattles.
  33. Place the instructions in the glove box after fitment.
-



# CUSTOMER INFORMATION

PLACE THESE INSTRUCTIONS IN THE  
VEHICLE'S GLOVEBOX AFTER INSTALLATION

**THANK YOU FOR PURCHASING HAYMAN REESE.  
WITH CORRECT MAINTENANCE AND CARE THIS PRODUCT WILL PROVIDE A  
LIFETIME OF TROUBLE-FREE OPERATION.**

## **i** TOWBAR MAINTENANCE AND CARE:

1. Hayman Reese recommend that the towbar LUG or TBM (tow ball Mount) Pull Pin and R-clip are removed and stored when not in use. Removal of LUG or TBM (tow ball mount) is advisable when not in use to assist with any of the following.
  - Ensure rear number plate is not obscured.
  - Allow maximum available departure angle and prevent any potential interference.
  - Prevent possible interference with vehicles reverse sensors or camera detecting a tow ball mount as an obstruction during reversing.
  - Removes towball mount as an obstruction for when moving around the rear of the vehicle.
2. Hayman Reese recommends routine inspection of your towbar to ensure trouble free towing.
  - Bolt security and tension should be regularly inspected and checked for correct tension. Replace any worn or defective parts with suitable grade & class fasteners. Inspection should be requested to coincide with vehicle major services.
3. It is the owner's responsibility to ensure towing and down ball weight capacities of the towing vehicle are not exceeded.
  - Towing and down ball weights allowable may differ according to model variations. Please refer to owner's manual or vehicle dealer to confirm exact rating for your vehicle model variant.
  - It is not uncommon for the vehicle tow rating to differ from the towbar rating. When this occurs, the lesser rating must be adhered to.
  - For vehicles fitted with enhanced vehicle functions that may be altered/changed when towing i.e Trailer sway mitigation, blind spot detection, adaptive cruise control etc. Please consult owner's manual to understand changes enabled when towing and after towing.

## **i** WARRANTY INFORMATION:

Hayman Reese Towbars are covered by a Lifetime Warranty.

Our goods come with guarantees that cannot be excluded under the Australian Consumer Law. You are entitled to a replacement or refund for a major failure and for compensation for any other reasonably foreseeable loss or damage. You are also entitled to have the goods repaired or replaced if the goods fail to be of acceptable quality and the failure does not amount to a major failure.

For further details please visit [www.haymanreese.com.au/warranty](http://www.haymanreese.com.au/warranty) or contact customer service on 1800 812 017 or [info@haymanreese.com.au](mailto:info@haymanreese.com.au).



# CUSTOMER INFORMATION

PLACE THESE INSTRUCTIONS IN THE VEHICLE'S GLOVEBOX AFTER INSTALLATION

## HAYMAN REESE SMART PIN

Your Hayman Reese towbar is equipped with Smart Pin technology to help reduce towbar tongue rattle in most driving conditions. Please ensure below instructions are understood and routine maintenance is carried out to ensure best towing experience.

**i** Regularly inspect for wear and check the tightness of the Smart Pin Nut. Follow instructions below to re-tighten the nut as necessary when movement and noise in the tow ball mount is noted.

- Before towing, ensure R-Clip is properly installed and Smart pin nut is installed and tensioned. Replacement parts are available from your Hayman Reese Distributor.

## TOWBALL MOUNT REMOVAL/INSTALLATION

### STEP 1

Insert Trailer Ball Mount (TBM) (a) into towbar hitchbox (b), aligning hole in TBM shank (c) with hole in hitchbox (d) (Fig. 1)

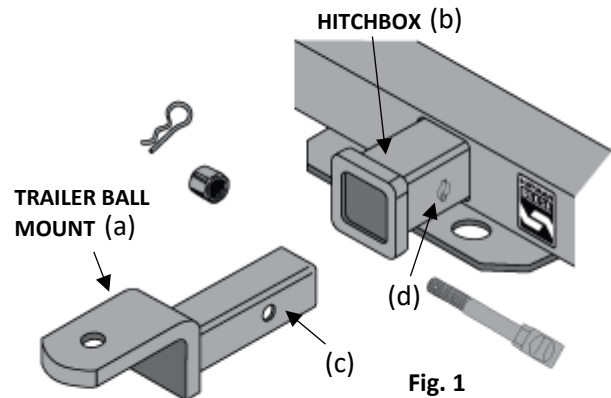

### STEP 2

Insert Smart Pin (e) through hole in hitchbox and hole in TBM shank (g); ensure the locators are inserted into the notches in the hitchbox (Fig. 2)

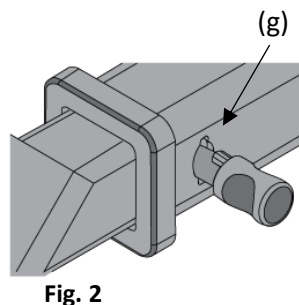

### STEP 3

Screw Smart Pin Nut (f) onto Smart Pin (g); tighten Smart Pin Nut until finger tight, ensuring TBM is restrained from up and down movement.

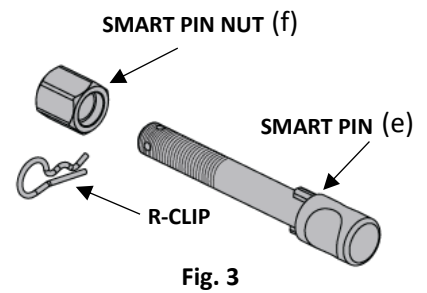

### STEP 4

Tighten Smart Pin Nut by turning nut a further 1/8th of a turn in the clockwise direction using a 24mm spanner (Fig. 4).

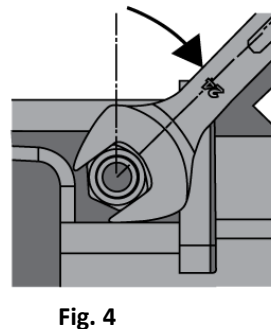

### STEP 5

Install Smart Pin R-Clip through the hole that provides best clearance or easiest access. (Fig. 5)

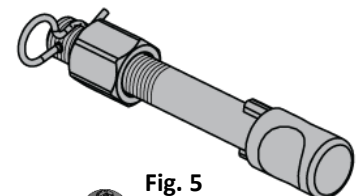

### STEP 6

Install towball onto TBM and tighten to **350 Nm** using a calibrated torque wrench (Fig. 6).

