



TOWBAR INSTALLATION INSTRUCTIONS

PART NUMBER 03408RW

FORD RANGER CL4 UTE MY22



PRODUCT DETAILS:

Part Number:	03408RW	Maximum Towing Braked:	3500	kg
ECU Number:	WLE70029	Maximum Towing Unbraked:	750	kg
Tail Harness Length Required:	1200mm	Maximum Static Ball Load:	350	kg
TBM/Lug Part Number:	21161			
Wiring Part Number:	WLL90029			

FITTING DETAILS:

Towbar Installation Time:	60 Mins.	Hayman Reese SmartCODE Solution Required:	YES
Wiring Installation Time:	30 Mins.	RPA Disable/Other:	YES
Total Installation Time:	90 Mins.		
Bumper Cut Required:	Yes		

Note:

- Please refer vehicles owner's manual for proper operation and understanding of towing features enabled when coded.
- For vehicles coded within the FORD dealer network using the FORD IDS tool. Aftermarket (AM) module must be selected.



TOWBAR INSTALLATION INSTRUCTIONS

PART NUMBER 03408RW

FORD RANGER CL4 UTE MY22

ENSURE THAT INSTRUCTIONS ARE UNDERSTOOD PRIOR TO FITMENT.

i BEFORE YOU START:

Hayman Reese recommends that instructions are read completely prior to fitment. Check all hardware items have been included refer to assembly diagram. Please ensure this towbar is only fitted to vehicle models as per Hayman Reese application guide (www.haymanreese.com.au).

Bumper Cuts



Vehicle and bumper variations can and do occur during vehicle manufacture after initial towbar design. Fitment of towbar to vehicle and accuracy of bumper cut must be assessed prior to any bumper modifications made. Incorrect bumper cuts are not covered under Hayman Reese warranty.

NOTE: Bumper cuts need to be approached with care, refer to notes below.

- Bumper centreline – where the centreline of the bumper needs to be determined, the installer must assess centre point by measurement of bumper width or determining two symmetrical reference points to give centreline.
- Bumper edge – To assist with accurate bumper cut measurement, reference to the start of the bumper edge is now being commonly used.
 - Measure from bottom edge along bumper and around corner to the 70 mm point (Figure 1).
 - Do not measure from visible bumper front of corner, upwards (Figure 2).

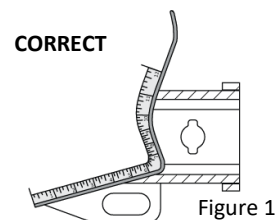

Figure 1

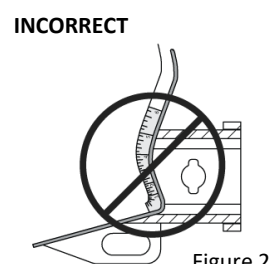

Figure 2

Drilling

- For any required drilling during installation, ensure that the area is clear of fuel, electrical & other components that may be damaged.
- All holes drilled into the body panels shall have all burrs & swarf removed then coated with a suitable rust preventative paint.

Bolts/Fasteners

- Ensure that all hardware is fastened to correct torque as specified in this fitting instruction.
- All fasteners supplied with this product are used to achieve a specified clamp loading. If replacement is required ensure that fasteners of the same grade and class are used.



NOTE: Achieving correct torque is critical to proper installation and responsibility of the installer. Towbar failures attributed to tension issues from over tightening or under tightening are not covered by Hayman Reese warranty.

Product Labels

- a. Towbar load rating sticker provided with this product shall be conspicuously located on inside rear end of the driver's door.
- b. Powertrain Control Module (PCM)/Body Control Module (BCM) upgrade warning label will be provided in towbar kit for vehicles as required. Affix warning label in door and owner's handbook.

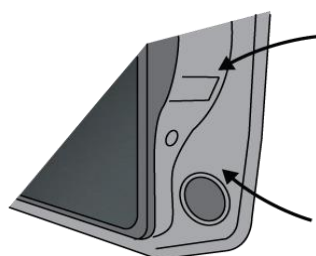

Place **Load Rating sticker** inside driver's door here

Place **Vehicle PCM/ BCM upgrade warning label** in door AND on front cover of owner's service handbook

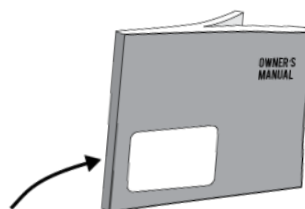

WARNING:

Do not, drill, cut, weld or otherwise modify the towbar.

FOR TOWING PURPOSES ONLY - This towbar is designed and tested by Hayman Reese to adhere to ADR 62/02 which provides only for the expected load demands of towing.



TOWBAR INSTALLATION INSTRUCTIONS

PART NUMBER 03408RW

FORD RANGER CL4 UTE MY22

i TOWBAR ASSEMBLY DIAGRAM

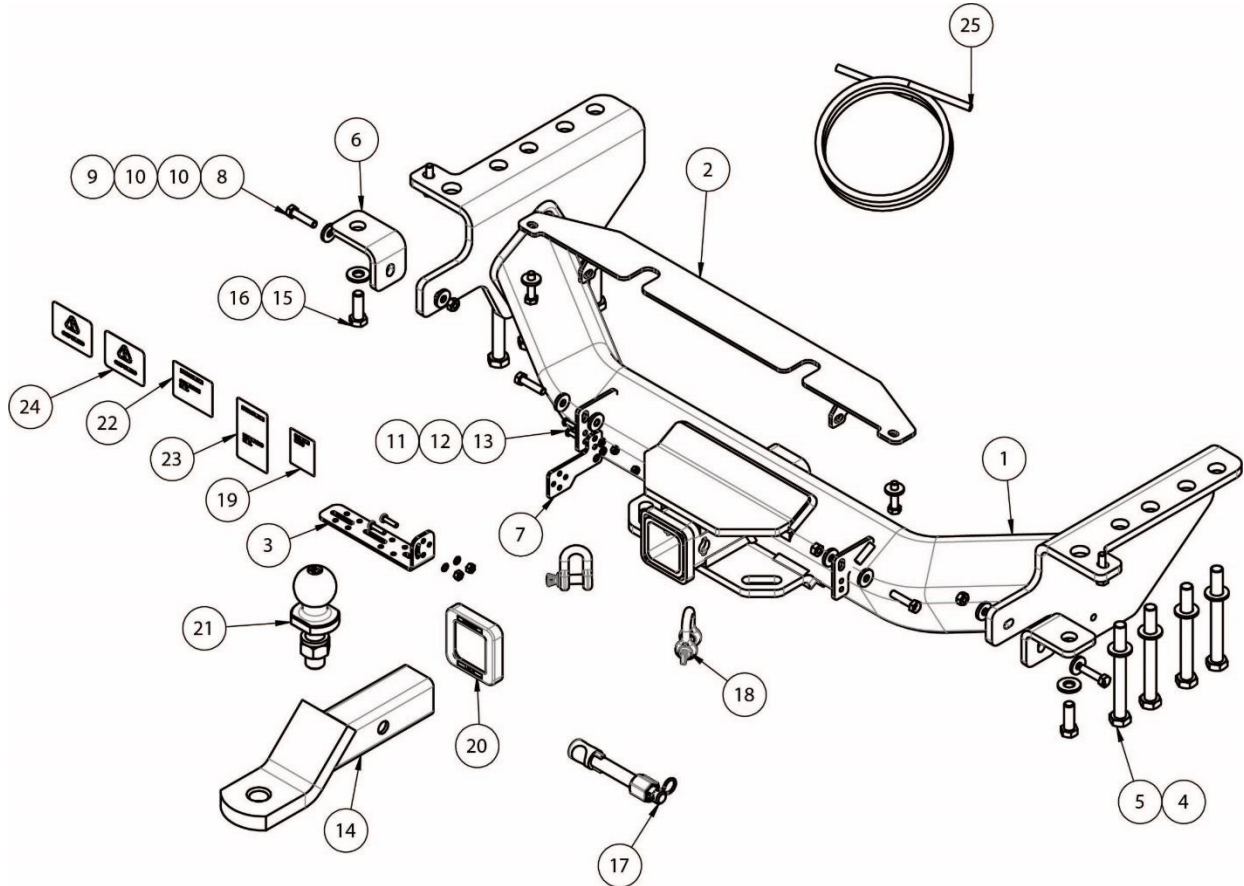

ITEM	DESCRIPTION	QTY
1	FORD RANGER WELDED ASSEMBLY	1
2	STEP WELDED ASSEMBLY	1
3	LARGE UNIVERSAL PLUG BRKT KIT	1
4	WASHER PLAIN M14x28x3.0	8
5	BOLT HEX HD M14x130x2.0P	8
6	BRACKET - STEP	2
7	PLUG BRACKET 2	1
8	BOLT HEX HD M8x35x1.25P	4
9	NUT HEX HD M8x1.25P	4
10	WASHER PLAIN M8x22x3	8
11	NUT NYLOC INS HEX HD M5x0.8P	2
12	WASHER PLAIN M5x10x1	2
13	SCREW PAN XR M5x16x0.8P	2

ITEM	DESCRIPTION	QTY
14	TRAILER BALL MOUNT	1
15	BOLT HEX HD M12x35x1.75P	2
16	WASHER PLAIN 1/2"	2
17	SMART PIN GOLD	1
18	10mm "D" SHACKLE	2
19	HAYMAN REESE LOGO STICKER	1
20	HITCH BOX COLLAR COVER	1
21	TOWBALL 50mm	1
22	COMPLIANCE LABEL	1
23	LOAD RATING LABEL	1
24	CAN MODULE WARNING LABEL	2
25	WIRING LOOM	1

1. On the LHS of the chassis, locate the vehicle rear step 16-way wiring connector and disconnect.

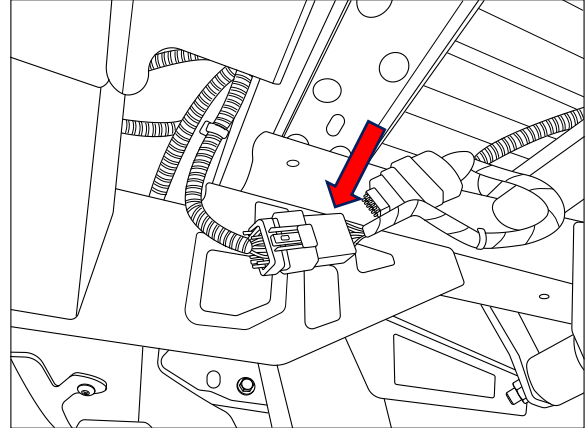

2. On the RHS of the under carriage remove the following fasteners:
2x M8
1x M10

Repeat for the other side.

Remove rear step and store in a safe place.

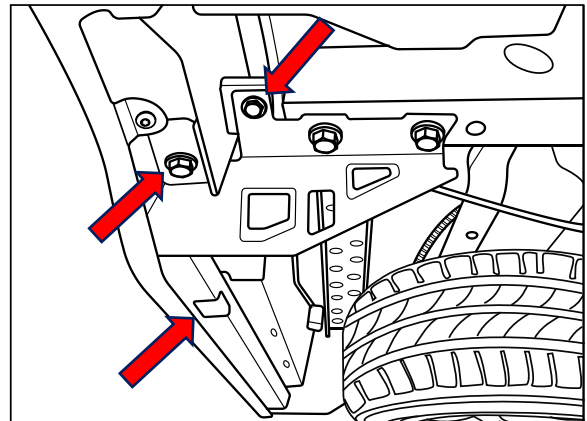

3. Remove 4x M14 bolts that secure the rear step support bracket and discard both bracket and fasteners.

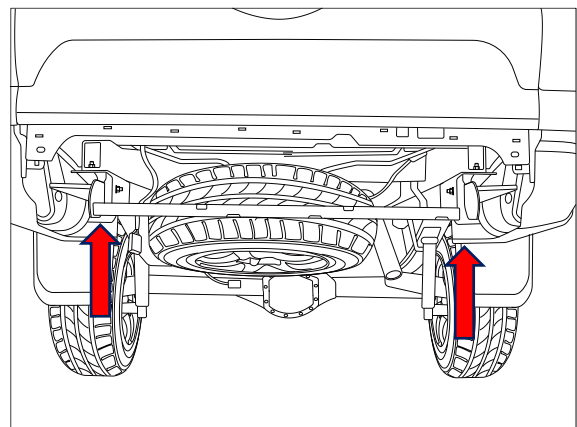



TOWBAR INSTALLATION INSTRUCTIONS

PART NUMBER 03408RW

FORD RANGER CL4 UTE MY22

4. Loosely assemble the components to the towbar as shown, using fasteners identified on Page 3.

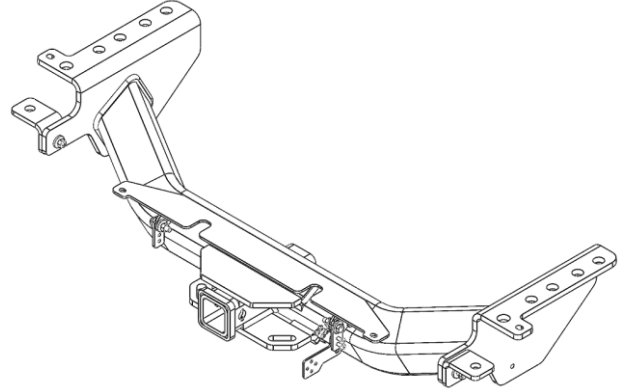

5. Place the tow bar to chassis and loosely secure with 4x M14 bolts and 4x washer.

Repeat for the other side

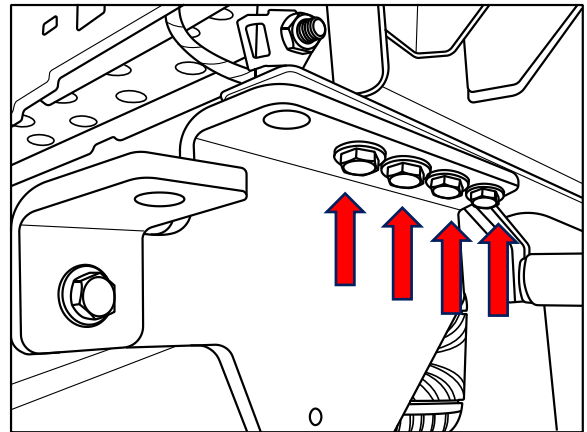

6. Determine the centre light of the garnish, mark of as per image mark a line 20mm down from the feature line.

7. Cut out a section 85mm wide.

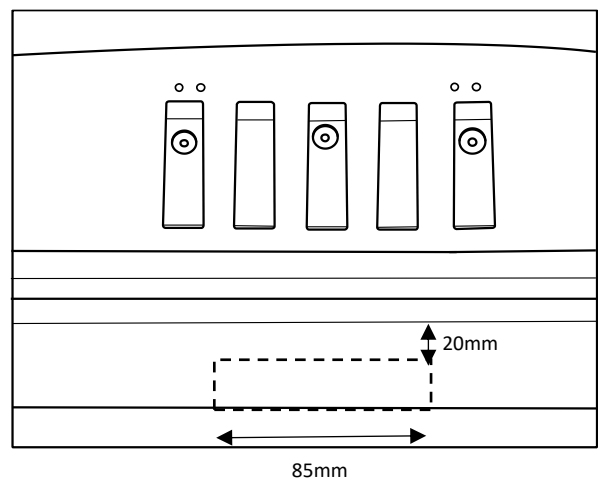



TOWBAR INSTALLATION INSTRUCTIONS

PART NUMBER 03408RW

FORD RANGER CL4 UTE MY22

8. Refit the rear step to vehicle align and secure the step brackets M8 and M12 bolts.
9. Reconnect the rear step connector.

Torque fasteners as follows:

M14 x 2.0P = 170 Nm

M12 x 1.75P = 109 Nm

M8 x 1.25P = 22Nm

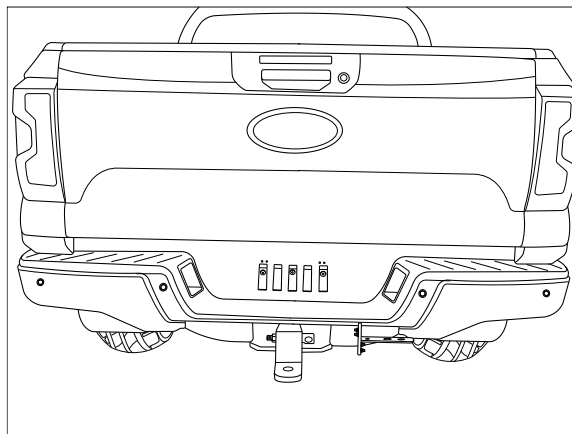

10. On the LHS under carriage, locate and disconnect the blanking connector from the 16-way trailer output Pre-Wire connector.

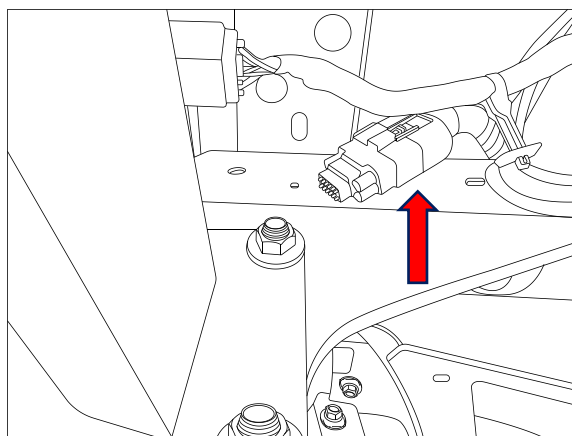

11. Connect the trailer patch (WLL90029) to the vehicle mating connector.
12. Mount the trailer plug to plug bracket, route the tail blue connector towards trailer patch mating connector.
13. **Connect and waterproof the blue connector using electrical grease or silicon.**

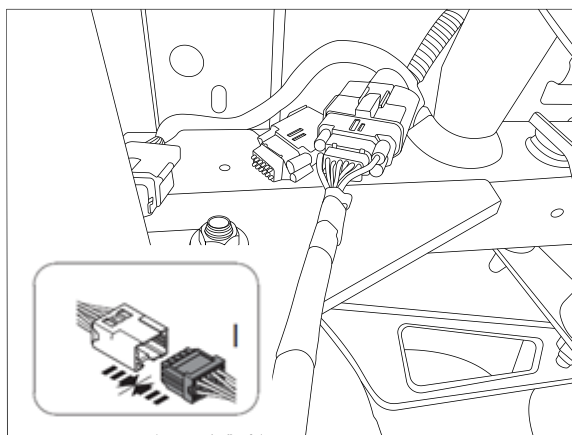

14. From inside the LHS of vehicle remove the following interior trims.

- Dislodge the door seal.
- Remove and detach the glove box. **(When open pull in the side stoppers).**
- Remove the end dash trim.
- Remove the fastener that's secures the front fascia trim, unclip the trim.

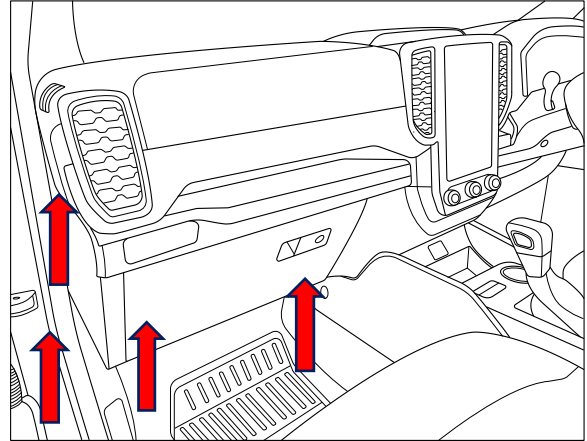

15. Remove the Gateway module 3x fasteners.
16. Move the module enough to gain access the trailer Pre-wire connectors.

Note: Care must be taken when moving the module.

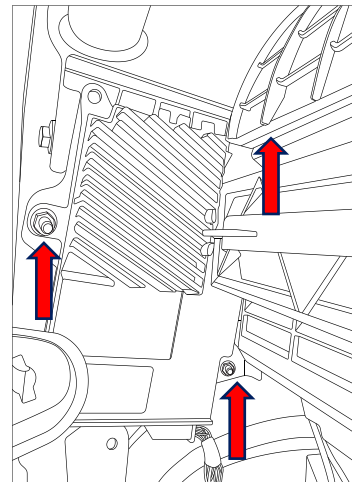

17. Using a flat blade screwdriver release the connector tabs for the 3x trailer pre-wire connectors.

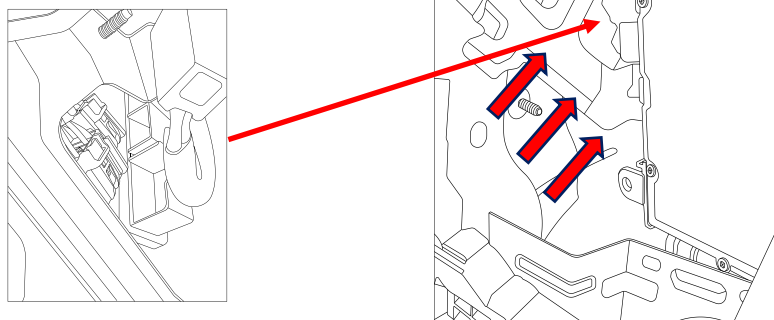

18. From underneath the LHS footwell pull down the released connectors.

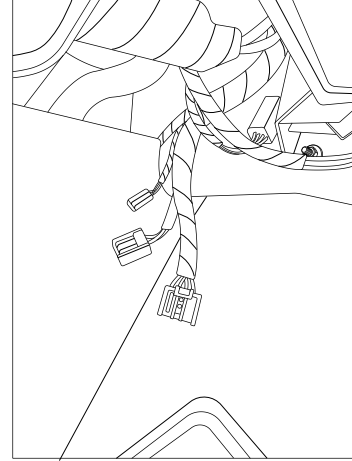

19. Connect the trailer patch (WLL90029) interior harness to mating connectors.

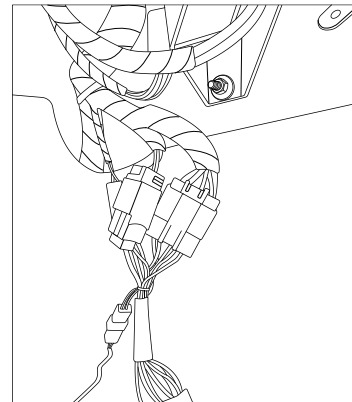

20. Connect the trailer patch connector to the ECU (WLE70029).
21. Remove the ECU adhesive backing tape and secure the module in behind the LHS footwell.

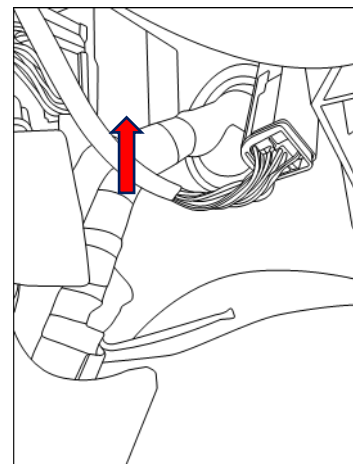



TOWBAR INSTALLATION INSTRUCTIONS

PART NUMBER 03408RW

FORD RANGER CL4 UTE MY22

22. Refit all removed parts from steps 14- 16 in reverse.
23. Test the functionality of trailer module ensuring all lights work using a trailer test board.
24. Next step is coding of vehicle.
25. Pay attention to the “SmartCODE” instruction page.
26. Once vehicle is coded test trailer functionality with a test board.

Place fitting instructions in glovebox when finished.



CUSTOMER INFORMATION

PLACE THESE INSTRUCTIONS IN THE VEHICLE'S GLOVEBOX AFTER INSTALLATION

**THANK YOU FOR PURCHASING HAYMAN REESE.
WITH CORRECT MAINTENANCE AND CARE THIS PRODUCT WILL PROVIDE A
LIFETIME OF TROUBLE-FREE OPERATION.**

i TOWBAR MAINTENANCE AND CARE:

1. Hayman Reese recommend that the towbar LUG or TBM (tow ball Mount) Pull Pin and R-clip are removed and stored when not in use. Removal of LUG or TBM (tow ball mount) is advisable when not in use to assist with any of the following.
 - Ensure rear number plate is not obscured.
 - Allow maximum available departure angle and prevent any potential interference.
 - Prevent possible interference with vehicles reverse sensors or camera detecting a tow ball mount as an obstruction during reversing.
 - Removes towball mount as an obstruction for when moving around the rear of the vehicle.
2. Hayman Reese recommends routine inspection of your towbar to ensure trouble free towing.
 - Bolt security and tension should be regularly inspected and checked for correct tension. Replace any worn or defective parts with suitable grade & class fasteners. Inspection should be requested to coincide with vehicle major services.
3. It is the owner's responsibility to ensure towing and down ball weight capacities of the towing vehicle are not exceeded.
 - Towing and down ball weights allowable may differ according to model variations. Please refer to owner's manual or vehicle dealer to confirm exact rating for your vehicle model variant.
 - It is not uncommon for the vehicle tow rating to differ from the towbar rating. When this occurs, the lesser rating must be adhered to.
 - For vehicles fitted with enhanced vehicle functions that may be altered/changed when towing i.e Trailer sway mitigation, blind spot detection, adaptive cruise control etc. Please consult owner's manual to understand changes enabled when towing and after towing.

i WARRANTY INFORMATION:

Hayman Reese Towbars are covered by a Lifetime Warranty.

Our goods come with guarantees that cannot be excluded under the Australian Consumer Law. You are entitled to a replacement or refund for a major failure and for compensation for any other reasonably foreseeable loss or damage. You are also entitled to have the goods repaired or replaced if the goods fail to be of acceptable quality and the failure does not amount to a major failure.

For further details please visit www.haymanreese.com.au/warranty or contact customer service on 1800 812 017 or info@haymanreese.com.au.



CUSTOMER INFORMATION

PLACE THESE INSTRUCTIONS IN THE VEHICLE'S GLOVEBOX AFTER INSTALLATION

HAYMAN REESE SMART PIN

Your Hayman Reese towbar is equipped with Smart Pin technology to help reduce towbar tongue rattle in most driving conditions. Please ensure below instructions are understood and routine maintenance is carried out to ensure best towing experience.

i Regularly inspect for wear and check the tightness of the Smart Pin Nut. Follow instructions below to re-tighten the nut as necessary when movement and noise in the tow ball mount is noted.

- Before towing, ensure R-Clip is properly installed and Smart pin nut is installed and tensioned. Replacement parts are available from your Hayman Reese Distributor.

TOWBALL MOUNT REMOVAL/INSTALLATION

STEP 1

Insert Trailer Ball Mount (TBM) (a) into towbar hitchbox (b), aligning hole in TBM shank (c) with hole in hitchbox (d) (Fig. 1)

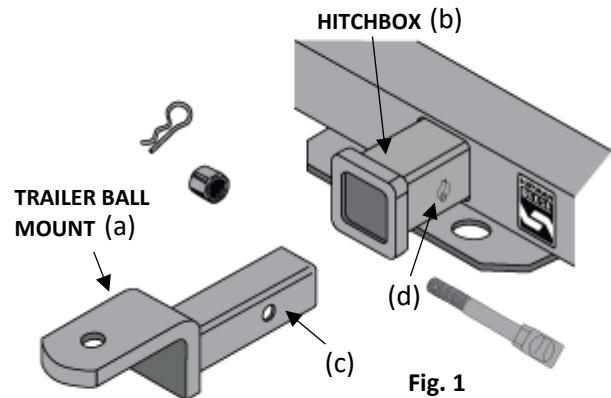

STEP 2

Insert Smart Pin (e) through hole in hitchbox and hole in TBM shank (g); ensure the locators are inserted into the notches in the hitchbox (Fig. 2)

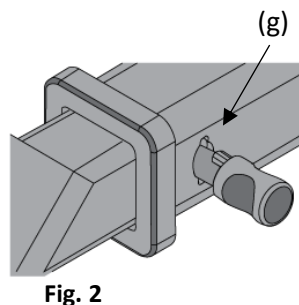

STEP 3

Screw Smart Pin Nut (f) onto Smart Pin (g); tighten Smart Pin Nut until finger tight, ensuring TBM is restrained from up and down movement.

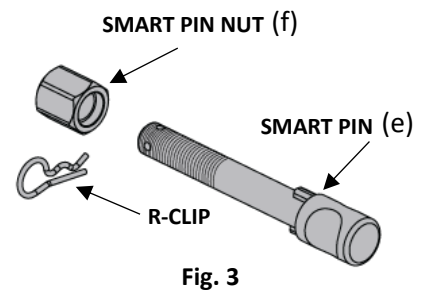

STEP 4

Tighten Smart Pin Nut by turning nut a further 1/8th of a turn in the clockwise direction using a 24mm spanner (Fig. 4).

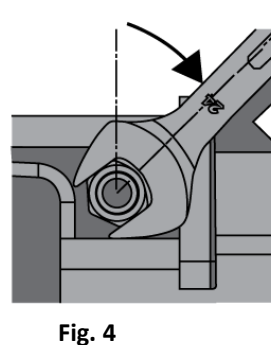

STEP 5

Install Smart Pin R-Clip through the hole that provides best clearance or easiest access. (Fig. 5)

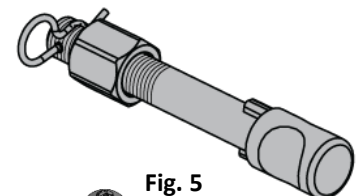

STEP 6

Install towball onto TBM and tighten to **350 Nm** using a calibrated torque wrench (Fig. 6).

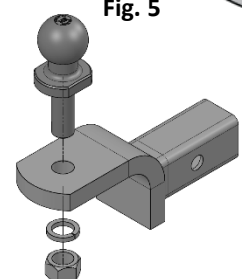

Appendix



WARNING: This vehicle requires a system setting to ensure the trailer wiring and control module are correctly recognised. This process (referred to as 'coding') must be carried out to enable correct vehicle functionality when trailer is connected. Towing features enabled by correct control module and coding support OE functionality as set by OE manufacturer. Please read the vehicles owner's manual for proper operation and understanding.

Coding can be carried out using the Hayman Reese SmartCODE (HRSC) using the following steps. Note, if HRSC is unavailable, vehicle coding can be carried out by OE manufacturer as needed.

Before you start:

- **Ensure the HRSC software is up to date using the HAYMAN REESE SMARTCODE PC APP.**
 - **Ensure the vehicle battery is fully charged**
 - **Use of a battery support unit (BSU) is advised during the coding process.**
 - **Ensure towbar, wiring loom and ECU are correctly installed as per Hayman Reese fitting instructions.**
1. Locate the OBD2 port under the drivers footwell on the right-hand side and plug in the HRSC.
 2. Close all doors and turn the ignition on
 3. Follow the directions on the screen of the HRSC
 4. Once the vehicle has been coded successfully proceed to the "clear codes" tab
 5. Remove disconnect HRSC from OBD2 port.
 6. Check the dash to make sure there are no warning faults.
 7. Check the operation of trailer lights and ensure the Reverse Park Assist (RPA) is disabled and 'trailer on' icon is active where available.

For technical support and further information on Hayman Reese SmartCODE tool and coding process contact your nearest Hayman Reese stockist.

Australia: 1800 812 017

New Zealand: 0800 237 886