



TOWBAR INSTALLATION INSTRUCTIONS

PART NUMBER 03331RW

FORD TRANSIT CUSTOM VAN VN CN CL4



PRODUCT DETAILS:

Part Number:	03331RW	Maximum Towing Braked:	2800	kg
ECU Number:	WLE70003	Maximum Towing Unbraked:	750	kg
Tail Harness Length Required:	1800 mm	Maximum Static Ball Load:	280	kg
TBM/Lug Part Number:	21346/21374			
Wiring Part Number:	WLL90013			

FITTING DETAILS:

Towbar Installation Time:	30 Mins.	Hayman Reese SmartCODE Solution Required:	YES
Wiring Installation Time:	30 Mins.	RPA Disable/Other:	YES
Total Installation Time:	60 Mins.		
Bumper Cut Required:	No		

Note:

- Please refer vehicles owner's manual for proper operation and understanding of towing features enabled when coded.
- Electric brake input location: Blue Wire near Blue Connector



TOWBAR INSTALLATION INSTRUCTIONS

PART NUMBER 03331RW

FORD TRANSIT CUSTOM VAN VN CN CL4

ENSURE THAT INSTRUCTIONS ARE UNDERSTOOD PRIOR TO FITMENT.

i BEFORE YOU START:

Hayman Reese recommends that instructions are read completely prior to fitment. Check all hardware items have been included refer to assembly diagram. Please ensure this towbar is only fitted to vehicle models as per Hayman Reese application guide (www.haymanreese.com.au).

Bumper Cuts



Vehicle and bumper variations can and do occur during vehicle manufacture after initial towbar design. Fitment of towbar to vehicle and accuracy of bumper cut must be assessed prior to any bumper modifications made. Incorrect bumper cuts are not covered under Hayman Reese warranty.

NOTE: Bumper cuts need to be approached with care, refer to notes below.

- Bumper centreline – where the centreline of the bumper needs to be determined, the installer must assess centre point by measurement of bumper width or determining two symmetrical reference points to give centreline.
- Bumper edge – To assist with accurate bumper cut measurement, reference to the start of the bumper edge is now being commonly used.
 - Measure from bottom edge along bumper and around corner to the 70 mm point (Figure 1).
 - Do not measure from visible bumper front of corner, upwards (Figure 2).

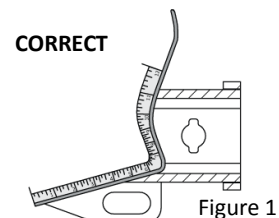

Figure 1

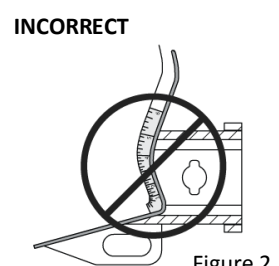

Figure 2

Drilling

- For any required drilling during installation, ensure that the area is clear of fuel, electrical & other components that may be damaged.
- All holes drilled into the body panels shall have all burrs & swarf removed then coated with a suitable rust preventative paint.

Bolts/Fasteners

- Ensure that all hardware is fastened to correct torque as specified in this fitting instruction.
- All fasteners supplied with this product are used to achieve a specified clamp loading. If replacement is required ensure that fasteners of the same grade and class are used.



NOTE: Achieving correct torque is critical to proper installation and responsibility of the installer. Towbar failures attributed to tension issues from over tightening or under tightening are not covered by Hayman Reese warranty.

Product Labels

- a. Towbar load rating sticker provided with this product shall be conspicuously located on inside rear end of the driver's door.
- b. Powertrain Control Module (PCM)/Body Control Module (BCM) upgrade warning label will be provided in towbar kit for vehicles as required. Affix warning label in door and owner's handbook.

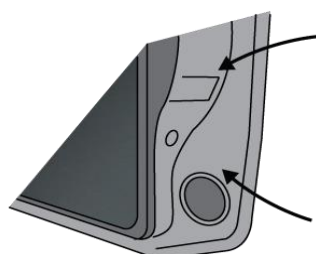

Place **Load Rating sticker** inside driver's door here

Place **Vehicle PCM/ BCM upgrade warning label** in door AND on front cover of owner's service handbook

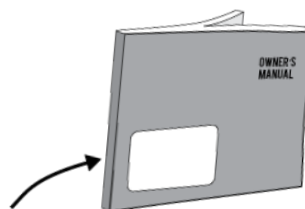

WARNING:

Do not, drill, cut, weld or otherwise modify the towbar.

FOR TOWING PURPOSES ONLY - This towbar is designed and tested by Hayman Reese to adhere to ADR 62/02 which provides only for the expected load demands of towing.



TOWBAR INSTALLATION INSTRUCTIONS

PART NUMBER 03331RW

FORD TRANSIT CUSTOM VAN VN CN CL4

TOWBAR ASSEMBLY DIAGRAM

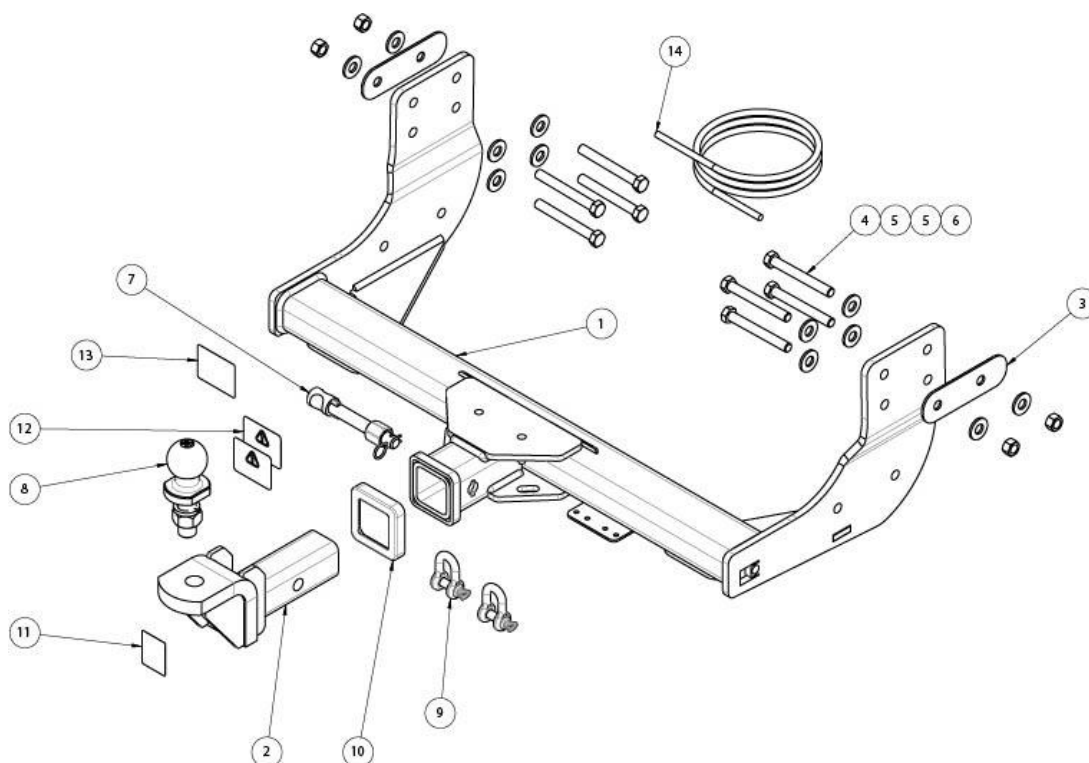

ITEM	DESCRIPTION	QTY
1	WELDED ASSEMBLY	1
2	TRAILER BALL MOUNT	1
3	SPACER	2
4	BOLT HEX HD M12x100x1.75P	8
5	WASHER FLAT M12	12
6	NUT HEX HD M12x1.75P	4
7	SMART PIN GOLD	1
8	TOWBALL 50mm	1
9	"D" SHACKLE 10mm	2
10	HITCH BOX COLLAR COVER	1
11	HAYMAN REESE LOGO STICKER	1
12	CAN WARNING LABEL	2
13	COMPLIANCE LABEL	1
14	WIRING LOOM	1



TOWBAR INSTALLATION INSTRUCTIONS

PART NUMBER 03331RW

FORD TRANSIT CUSTOM VAN VN CN CL4

1. Remove 2x Bolts securing rear intrusion beam to inside face of chassis rail. Repeat for opposite side of vehicle.

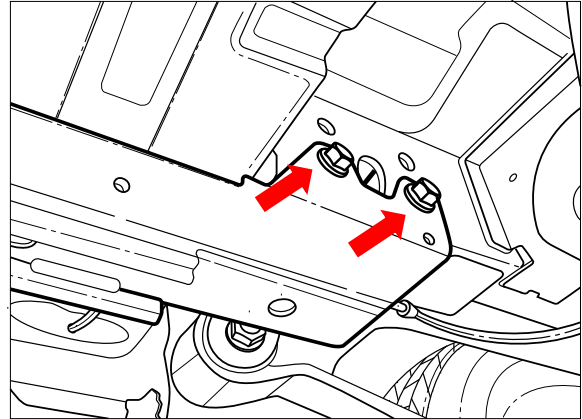

2. Loosely secure towbar to the lower inside face of chassis rail, using 2x M12 Bolts, complete with 1x Flat washer per Bolt. Repeat for opposite side of vehicle.
3. Insert spacer between upper mounting points of towbar side arm and chassis rail and loosely secure towbar to inside face of chassis rail, using 2x M12 Bolts, complete with 2x Flat Washers and 1x Nut per Bolt. Repeat for opposite side of vehicle.

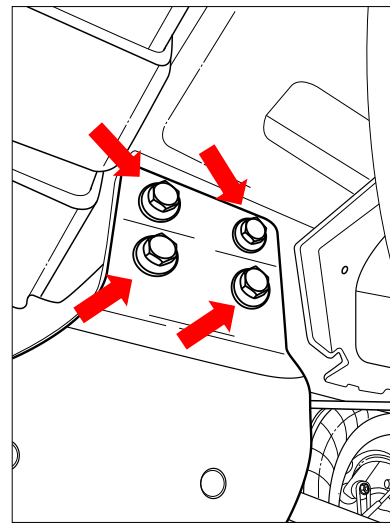

4. Position the towbar and tighten all fasteners to the following torque.

M12 : 130Nm

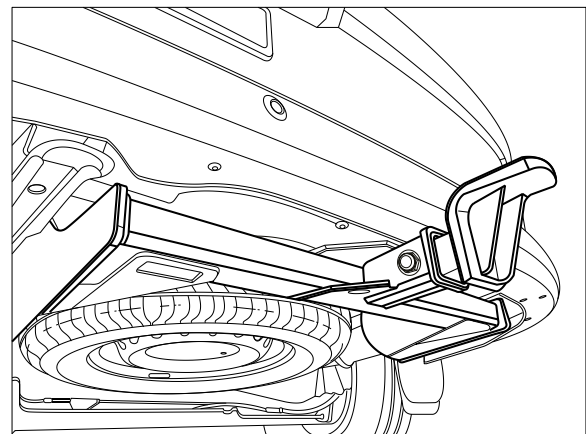



TOWBAR INSTALLATION INSTRUCTIONS

PART NUMBER 03331RW

FORD TRANSIT CUSTOM VAN VN CN CL4

IMPORTANT

Due to possible vehicle variations, always confirm any noted vehicle colour wires with a multi-meter to ensure the correct function is identified before soldering or scotch locking. For vehicle wires denoted with two colours (example; RED/GREEN) the first colour will always be the main wire colour while the second colour is the thinner trace colour on the wire.

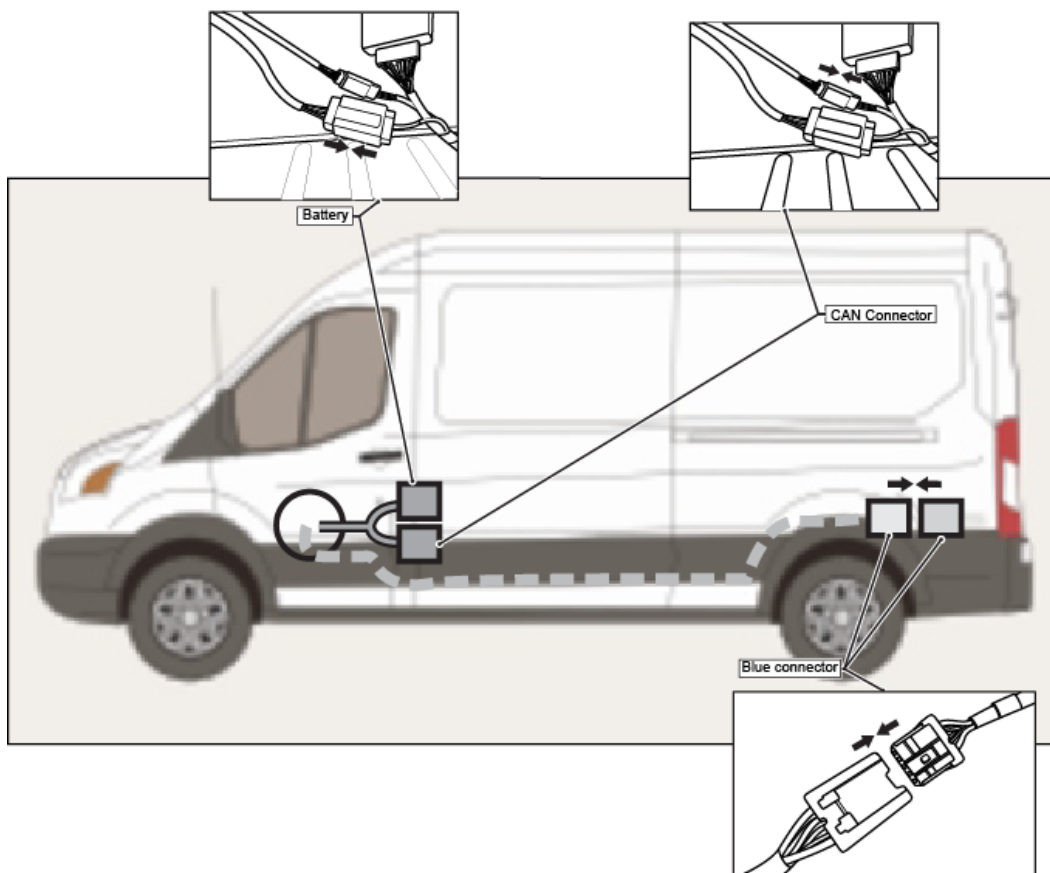

5. Inside the vehicle compartment, on the passenger side, remove a small section of the weather seal (1) covering the "B" pillar trim (2).
6. Dislodge and remove the "B" pillar middle trim (2) and then the "B" pillar lower trim (3).
7. Remove the white trim clip under the lower "B" pillar trim securing the step trim (4).

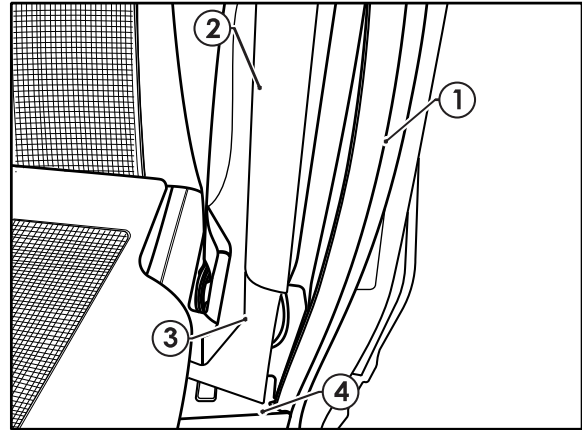

8. On the passenger foot well area, remove the 3 caps (1) on the step trim (2).
9. Remove the 3 Torx screws securing the step trim.
10. Dislodge and remove the step trim.

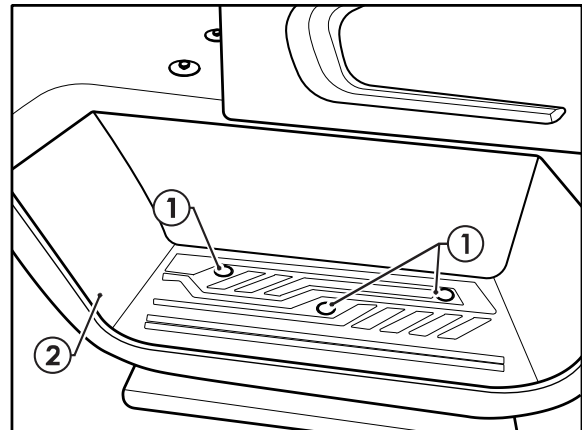

11. Locate the vehicle power (1) and CAN connectors (2) under the previously removed step trim.
12. Remove the tape and connect both the CAN (2) and power connectors (1) to their mating connectors on the patch loom (WLL90013).
13. Drill a 30mm grommet hole (3) through the floor.

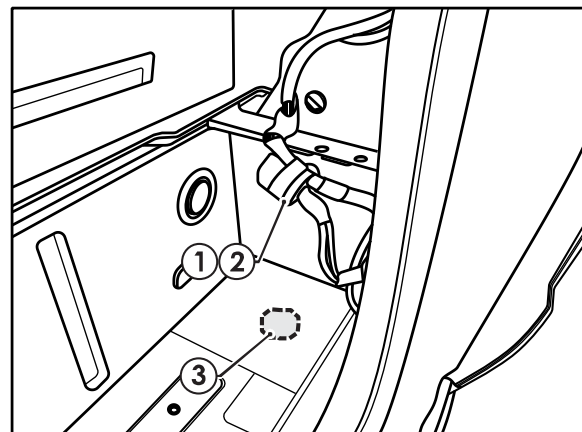

14. Route the long branch on the patch loom (1) through the grommet hole (2) and seat the grommet (3) in the hole.

Note: Ensure grommet is seated correctly and makes a good seal.

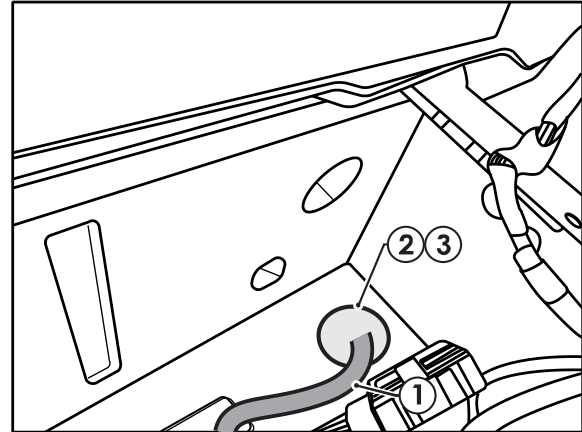

15. Using an alcohol wipe, clean a suitable area of sheet metal (1) and the underside of the ECU (WLE70003) (2).

16. Connect the trailer patch 18-way connector (3) to the ECU.

17. Apply double sided tape (4) to the ECU (2) and secure it to the vehicle sheet metal.

Note: Mount the ECU, ensuring the connector is orientated downwards.

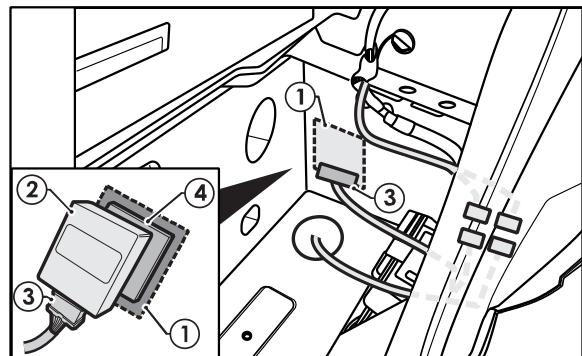

18. Under the vehicle passenger side, route the connector on the patch loom (1) rearwards towards the towbar.

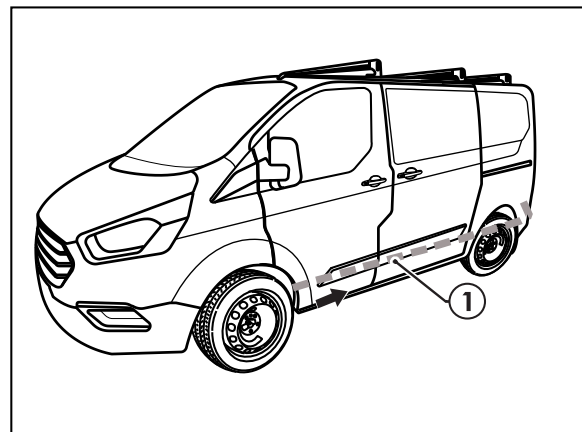



TOWBAR INSTALLATION INSTRUCTIONS

PART NUMBER 03331RW

FORD TRANSIT CUSTOM VAN VN CN CL4

19. Secure the tail harness to the towbar.
20. Route the tail harness blue connector towards blue connector on the patch loom.

Note: Keep harness routing clear of all sharp edges, moving parts and places of extreme heat.

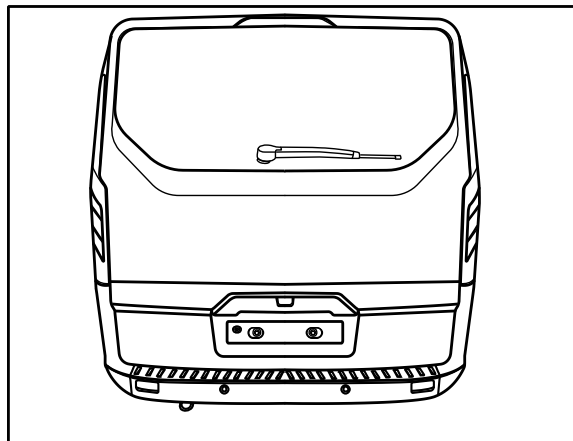

21. Connect the tail harness 8-way connector (1) to the trailer patch mating 8-way connector (2).
22. Apply silicone grease (not supplied) (3) to waterproof connector.

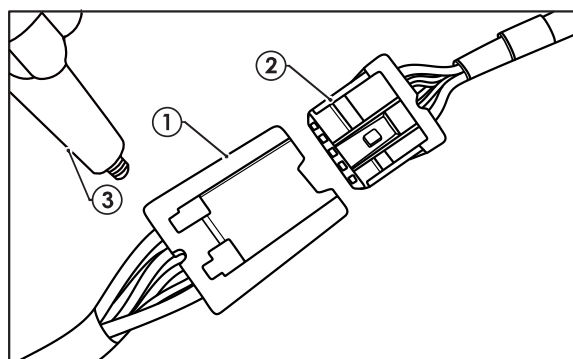

23. Re-fit all removed parts and secure all fasteners, ensuring there are no squeaks or rattles.
24. Test the trailer patch function using a light board.
25. Next step is code of vehicle. Pay attention to the "SmartCode" Instruction page (Appendix).
26. Place the fitting instructions in the glove box after fitment.



CUSTOMER INFORMATION

PLACE THESE INSTRUCTIONS IN THE
VEHICLE'S GLOVEBOX AFTER INSTALLATION

**THANK YOU FOR PURCHASING HAYMAN REESE.
WITH CORRECT MAINTENANCE AND CARE THIS PRODUCT WILL PROVIDE A
LIFETIME OF TROUBLE-FREE OPERATION.**

i TOWBAR MAINTENANCE AND CARE:

1. Hayman Reese recommend that the towbar LUG or TBM (tow ball Mount) Pull Pin and R-clip are removed and stored when not in use. Removal of LUG or TBM (tow ball mount) is advisable when not in use to assist with any of the following.
 - Ensure rear number plate is not obscured.
 - Allow maximum available departure angle and prevent any potential interference.
 - Prevent possible interference with vehicles reverse sensors or camera detecting a tow ball mount as an obstruction during reversing.
 - Removes towball mount as an obstruction for when moving around the rear of the vehicle.
2. Hayman Reese recommends routine inspection of your towbar to ensure trouble free towing.
 - Bolt security and tension should be regularly inspected and checked for correct tension. Replace any worn or defective parts with suitable grade & class fasteners. Inspection should be requested to coincide with vehicle major services.
3. It is the owner's responsibility to ensure towing and down ball weight capacities of the towing vehicle are not exceeded.
 - Towing and down ball weights allowable may differ according to model variations. Please refer to owner's manual or vehicle dealer to confirm exact rating for your vehicle model variant.
 - It is not uncommon for the vehicle tow rating to differ from the towbar rating. When this occurs, the lesser rating must be adhered to.
 - For vehicles fitted with enhanced vehicle functions that may be altered/changed when towing i.e Trailer sway mitigation, blind spot detection, adaptive cruise control etc. Please consult owner's manual to understand changes enabled when towing and after towing.

i WARRANTY INFORMATION:

Hayman Reese Towbars are covered by a Lifetime Warranty.

Our goods come with guarantees that cannot be excluded under the Australian Consumer Law. You are entitled to a replacement or refund for a major failure and for compensation for any other reasonably foreseeable loss or damage. You are also entitled to have the goods repaired or replaced if the goods fail to be of acceptable quality and the failure does not amount to a major failure.

For further details please visit www.haymanreese.com.au/warranty or contact customer service on 1800 812 017 or info@haymanreese.com.au.



CUSTOMER INFORMATION

PLACE THESE INSTRUCTIONS IN THE VEHICLE'S GLOVEBOX AFTER INSTALLATION

HAYMAN REESE SMART PIN

Your Hayman Reese towbar is equipped with Smart Pin technology to help reduce towbar tongue rattle in most driving conditions. Please ensure below instructions are understood and routine maintenance is carried out to ensure best towing experience.

i Regularly inspect for wear and check the tightness of the Smart Pin Nut. Follow instructions below to re-tighten the nut as necessary when movement and noise in the tow ball mount is noted.

- Before towing, ensure R-Clip is properly installed and Smart pin nut is installed and tensioned. Replacement parts are available from your Hayman Reese Distributor.

TOWBALL MOUNT REMOVAL/INSTALLATION

STEP 1

Insert Trailer Ball Mount (TBM) (a) into towbar hitchbox (b), aligning hole in TBM shank (c) with hole in hitchbox (d) (Fig. 1)

STEP 2

Insert Smart Pin (e) through hole in hitchbox and hole in TBM shank (g); ensure the locators are inserted into the notches in the hitchbox (Fig. 2)

STEP 3

Screw Smart Pin Nut (f) onto Smart Pin (g); tighten Smart Pin Nut until finger tight, ensuring TBM is restrained from up and down movement.

STEP 4

Tighten Smart Pin Nut by turning nut a further 1/8th of a turn in the clockwise direction using a 24mm spanner (Fig. 4).

STEP 5

Install Smart Pin R-Clip through the hole that provides best clearance or easiest access. (Fig. 5)

STEP 6

Install towball onto TBM and tighten to **350 Nm** using a calibrated torque wrench (Fig. 6).

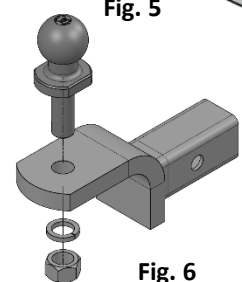
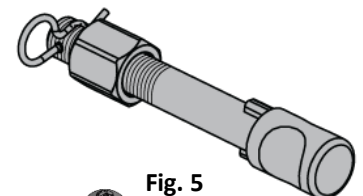
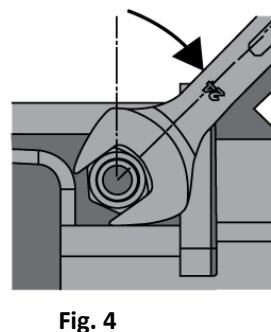
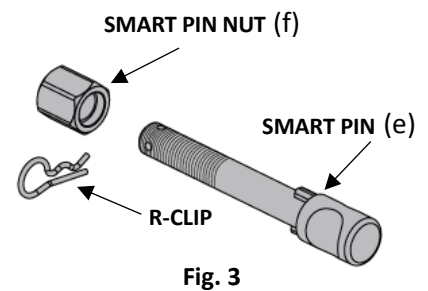
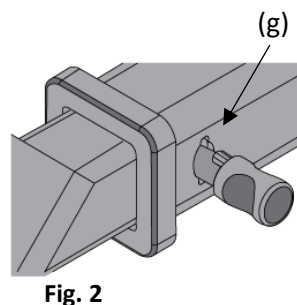
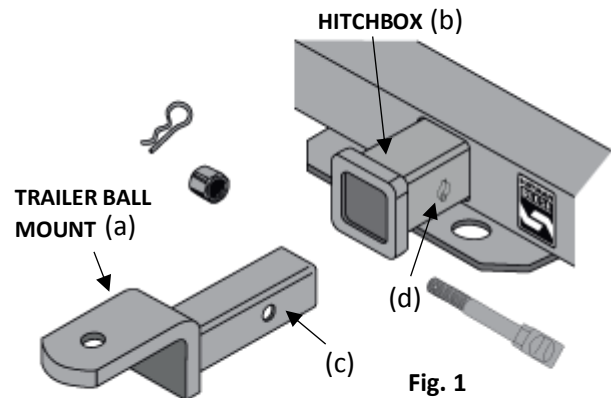



CUSTOMER INFORMATION

PLACE THESE INSTRUCTIONS IN THE
VEHICLE'S GLOVEBOX AFTER INSTALLATION

smartCODE
Intelligent towing



WARNING: This vehicle requires a system setting to ensure the trailer wiring and control module are correctly recognised. This process (referred to as 'coding') must be carried out to enable correct vehicle functionality when trailer is connected. Towing features enabled by correct control module and coding support OE functionality as set by OE manufacturer. Please read the vehicles owner's manual for proper operation and understanding.

Coding can be carried out using the Hayman Reese SmartCODE (HRSC) using the following steps. Note, if HRSC is unavailable, vehicle coding can be carried out by OE manufacturer as needed.

Before you start:

- **Ensure the HRSC software is up to date using the HAYMAN REESE SMARTCODE PC APP.**
 - **Ensure the vehicle battery is fully charged**
 - **Use of a battery support unit (BSU) is advised during the coding process.**
 - **Ensure towbar, wiring loom and ECU are correctly installed as per Hayman Reese fitting instructions.**
1. Locate the OBD2 port under the drivers footwell on the right-hand side and plug in the HRSC.
 2. Close all doors and turn the ignition on
 3. Follow the directions on the screen of the HRSC
 4. Once the vehicle has been coded successfully proceed to the "clear codes" tab
 5. Remove disconnect HRSC from OBD2 port.
 6. Check the dash to make sure there are no warning faults.
 7. Check the operation of trailer lights and ensure the Reverse Park Assist (RPA) is disabled and 'trailer on' icon is active where available.

For technical support and further information on Hayman Reese SmartCODE tool and coding process contact your nearest Hayman Reese stockist.

Australia: 1800 812 017

New Zealand: 0800 237 886