

# Kaymar

## Fitting Instructions



Suitable for

**100 LA L'CRUISER**

Year

Type **Wagon**

Part **Rear Bar**

**Applicable to Part Numbers**

**K3415U, KIT100U-LA, KIT100U-LA-R-JCD,  
KIT100U-LA-L-JCD**

Date published December 6, 2016

### **IMPORTANT - BEFORE COMMENCING INSTALLATION**

**Please verify the part number corresponds with the list above.**

**Read through these instructions and check items in the supplied fitting kit matches the attached list.**

Every effort is made to ensure instructions are as accurate as possible at the time of publishing however work should not be commenced until the document has been thoroughly read, measurements checked and all components in the package verified as complete. Kaymar has used reasonable care in preparing the information included in these documents, but makes no representations or warranties as to the completeness or accuracy of the information. Information is supplied upon the condition that the persons receiving the information will make their own determination as to its suitability for their purposes prior to use. Kaymar assumes no liability whatsoever for any damages incurred by you resulting from errors in or omissions from the information included herein. Kaymar reserves the right to make changes without further notice to any products to improve reliability, function or design.

### Suitable for TOYOTA 100 SERIES LIVE AXLE

Note: The rubber moulding trim strips must be glued to the top of the side wing panels of the Kaymar bar edges. 5 minute Araldite (use a very thin line of it) can be used.

1. Remove the original rear bumper, exhaust bracket, mud flaps and tow bar if fitted. Remove all mounting brackets from the chassis.  
Remove the chequer plate from the replacement bar.
2. Fit the two plates with nuts and wires on, into the chassis rails to line up with the corresponding holes in each chassis side.
3. Lift the bar onto the chassis, taking care not to hit the sides of the body with the long side panels of the bar.
4. Fit three each side, M12 x 35 long fine thread bolts, into the holes in the bottom of the chassis. Fit the spacer plates (1 double and 1 single slot), between the top of the main long arm and the bottom of the chassis on each side.

# Kaymar

## Fitting Instructions

5. Do these bolts up just tight enough so there is no gap between the bottom of the chassis and the spacer plate.
6. Fit two M12 x 35 bolts through each chassis side mount plate, into the plates with the nuts and wires welded on which you fitted in step 3.
7. Starting with the six along the bottom, tighten all bolts.
8. The two plates with tapped holes and wires welded on **MUST** be fitted in behind the centre mount plate on the bar. The bolts fit through the two holes in the centre of the rear main chassis cross member. The plate on wire is fed in from each side between the back of the bar and the chassis cross member. **Do these bolts up tight.**
9. The mud flaps can now be fitted using the original green plastic plugs and screws, into the holes in the ends of the bar side panels. Fit the mud flaps to the inner most bracket only. **DO NOT FIT THE OTHER TWO SCREWS INTO THE BODY**, then fit the remaining original screws into the plastic plugs in the bar. Because body heights vary on the chassis, you may need to slot the holes in the mud flap to fit the plastic plugs in the bar. Fit an original gold 8mm bolt with the nuts and washers supplied in the kit through the bottom of the mud flap and the tag on the bottom of the bar side plate.
11. Fit the chequer plate and plastic trim strip to the bar. (Apply a thin film of silicon to the top of the bar first).
12. Fit the wiring loom to the original loom underneath the body at the rear of the fuel tank. Feed each side wires through the chassis cross member and out of the bar through the top hole in the light mounting plate. The trailer plug is screwed onto the bottom angled face of the bar, approx. 150mm to the right of the tow hitch.
13. Fit the LED lights into the cutouts in the face of the bar and screw into the mounting bracket using the screws and nuts provided.
14. If a wheel carrier is to be fitted, use the black wire supplied in the number plate box to come from the centre pole in the trailer plug and through the back of the bar and out of the number plate light itself. Connect this to the angled terminal in the light, fit the globe and the cover. Mount the number plate to the bar next to the light. Use four 5/32 pop rivets.
15. Fit the wheel carrier by firstly greasing the pivot shaft and **GREASING THE TOP BEARING**. Slide the carrier onto the pivot shaft and fit the bearing, large washer and nut. Tighten the nut so as it is firm but not too tight. Fit the split pin. **FILL THE COVER CAP WITH GREASE** and fit it to the top of the carrier pivot.
16. Fit the wheel carrier and make sure to pull the tyre hard up against the frame, then tighten the two 16mm bolts in the top slide. **THIS MUST BE DONE**. Fit the wheel carrier handle catch as per diagram.

# Kaymar

## Fitting Instructions

**\*\*FOR BARN DOOR MODELS SEE DIAGRAM 2\*\***

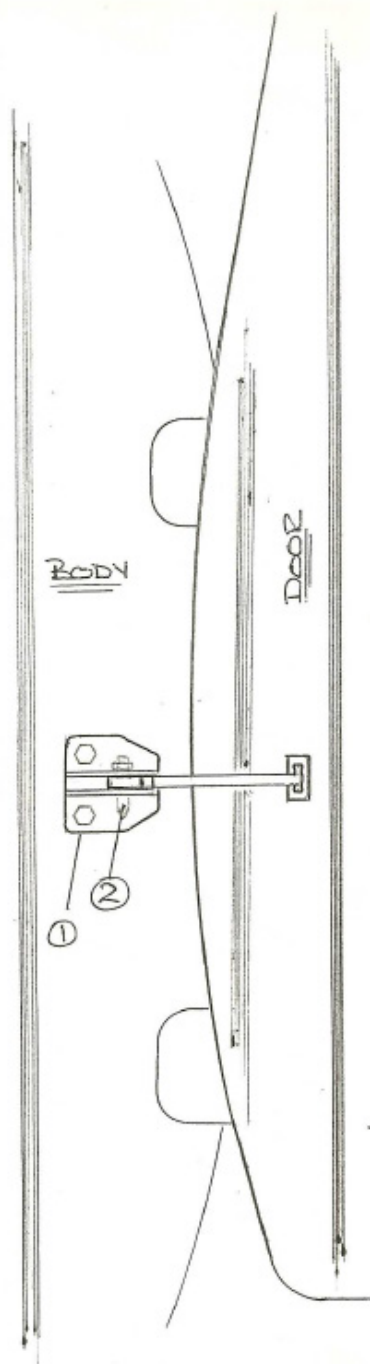

### Diagram 2

For: Toyota 80 series, 100 series, Toyota Troop Carrier STANDARD MODEL ONLY

#### BAR DOOR STOP ARM ADJUSTMENT

The door stop must be adjusted so as the door cannot open far enough to hit the wheel carrier.

Remove the pivot pin 2 by gently tapping it upwards with a small hammer.

Remove the two 6mm bolts which hold the bracket 1 to the body

Slot the two bolt holes so as the bracket can move towards the front of the vehicle 10mm.

Re-assemble on the vehicle if twin carriers are fitted this must be done to both doors

# Kaymar

## Fitting Instructions

### HANDLE FITTING DIMENSIONS

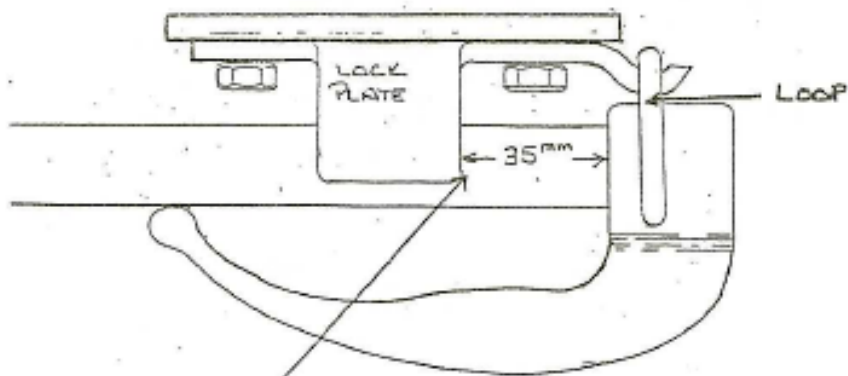

\* This dimension is important

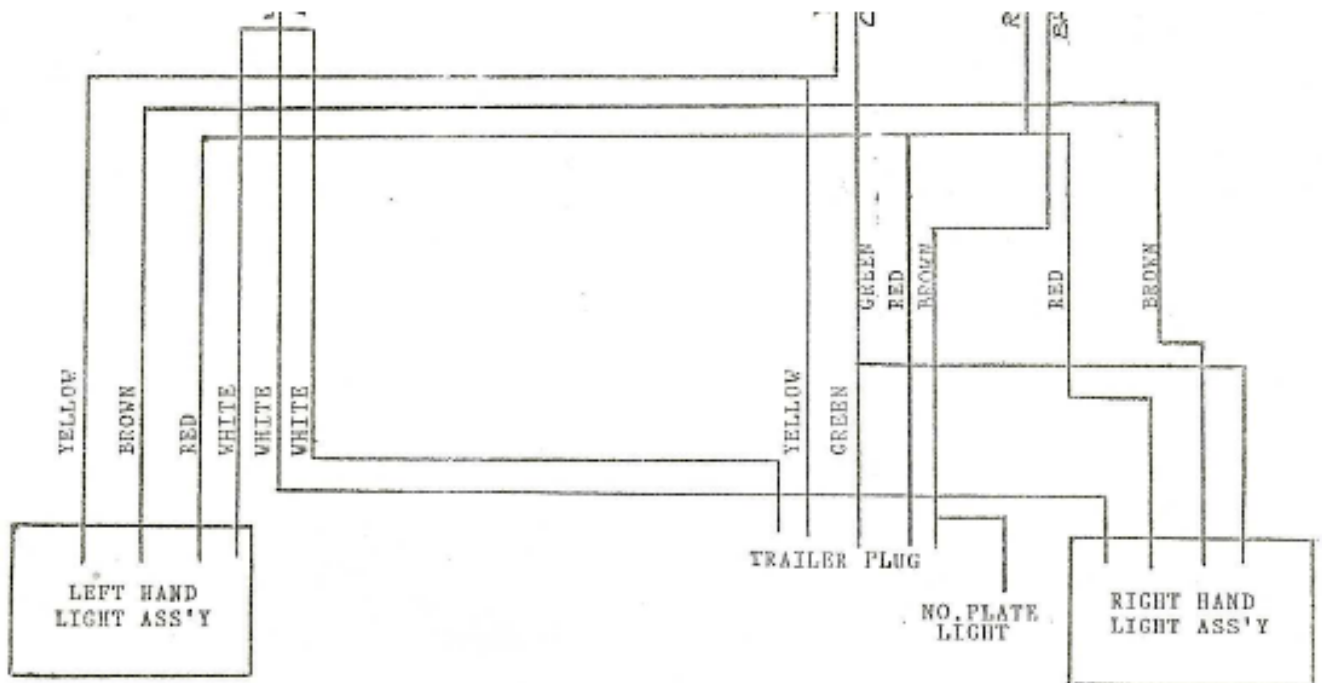

**Note: Toyota wiring loom Red/Black is Reverse**

# Kaymar

## Fitting Instructions

### LOCK TAB WASHER

1. Fit top slide (wheel holder) into wheel carrier.
2. Fit spring washer and small lock tab washer onto 16mm bolts.
3. Fit large 5mm thick washer onto bolt with lug {A} facing away from the head of the bolt.
4. Apply a thin film of grease to the bolts.
5. Screw 16mm bolt through the slots in the wheel carrier housing into the top slide. Make sure that the lug {A} fits into the slot first. Make sure you fit both bolts.
6. Fit the wheel and wheel lock plate.
7. Open the wheel carrier and stand behind it. **PULL THE TYRE INTO THE CARRIER FRAME SO THAT THE TYRE SITS HARD AGAINST THE FRAME.**
8. Tighten the two 16mm bolts to at least 140nm, make sure tab {B} fits into the cut-out in the 5 mm washer.
9. Continue turning the bolt until one flat on the hexagon is aligned with tab {C} of the lock tab washer.
10. Flatten tab {C} onto a flat of the hexagon on the bolt head. Do the same with both bolts. Make sure the whole tab sits flat on the bolt head.

**THIS MUST BE DONE.**

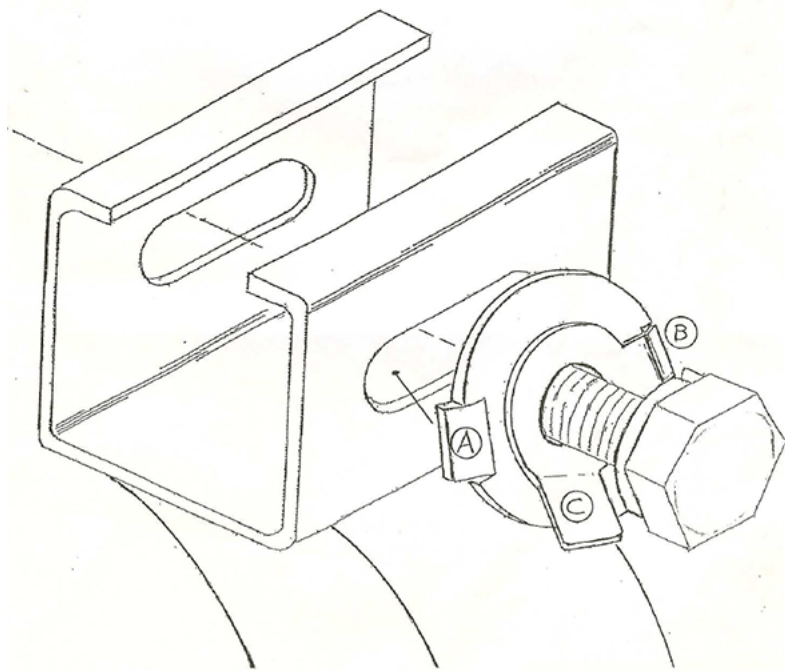

# Kaymar

## Fitting Instructions

### BK3415 100 SERIES LIVE AXLE REAR BAR

QUANTITY	DESCRIPTION
----------	-------------

6	BOLT M12 X 50 X 1.25 FINE THREAD
---	----------------------------------

6	BOLT M12 X 35 X 1.75
---	----------------------

12	WASHER FLAT M12 X 30 HD
----	-------------------------

12	WASHER SPRING M12
----	-------------------

1	BACKING PLATE - 2 X 12MM WELD NUTS ON 300 MM WIRE 80U L
---	---

1	BACKING PLATE - 2 X 12MM WELD NUTS ON 300 MM WIRE 80U R
---	---

2	TAPPED PLATE ON WIRE M12X1.75 300MM
---	-------------------------------------

2	PACKER DOUBLE SLOT 3MM 95X50 "M"
---	----------------------------------

2	PACKER DOUBLE SLOT 8MM 95X50 "M"
---	----------------------------------

2	PACKER SINGLE SLOT 3MM 50X50 "N"
---	----------------------------------

2	PACKER SINGLE SLOT 8MM 50X50 "N"
---	----------------------------------

2	WASHER FLAT M8 X 17
---	---------------------

2	WASHER SPRING M8
---	------------------

2	NUT M8 X 1.25
---	---------------

4	POP RIVET 5/32
---	----------------

10	WIRE CONNECTOR MALE
----	---------------------



*backing\_plate\_2x\_12mm\_welded\_nuts\_ on\_300mm\_wire\_80UL*



*backing\_plate\_2x\_12mm\_welded\_nuts\_ on\_300mm\_wire\_80UR*



*tapped\_plate\_on\_wire\_M12x1.75\_300mm*



*packer\_double\_ slot\_3mm\_95x50\_M*



*packer\_double\_ slot\_8mm\_95x50\_M*

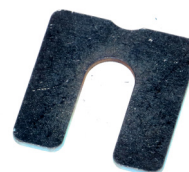

*packer\_single\_ slot\_3mm\_50x50\_N*



*packer\_single\_ slot\_8mm\_50x50\_N*