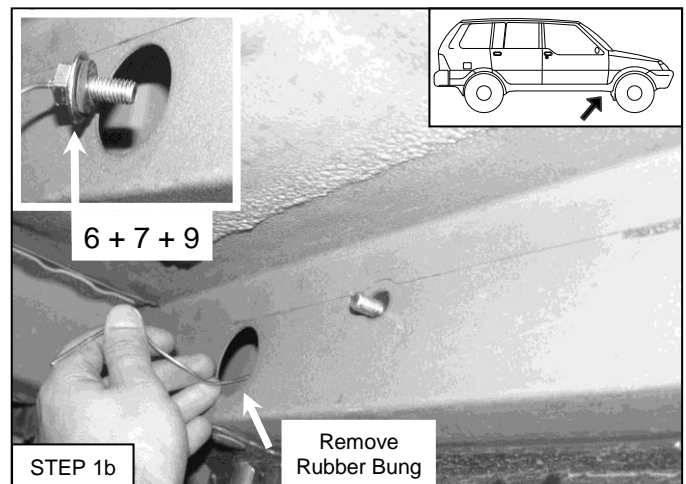
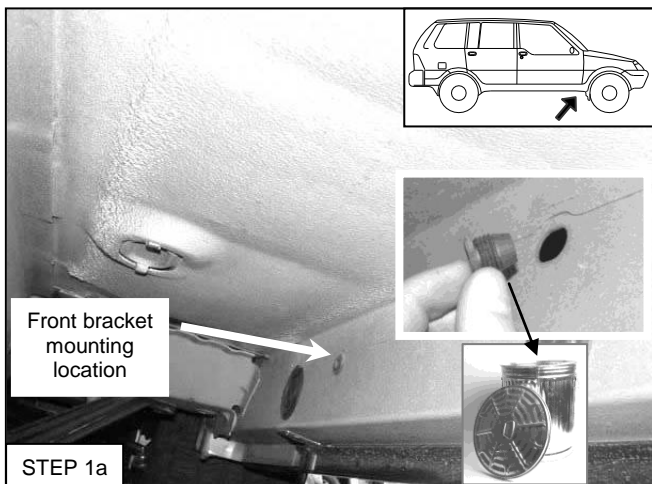

KINGSLEY***INTEGRA STEP®*****FITTING INSTRUCTIONS****Part No: 30F600****FORD TERRITORY 4WD & 2WD****Model Commencing 04/2004****ENDCAPS:** Front - fitted with Standard endcaps
Rear - fitted with Standard endcaps**STEPPADS:** Front - 1 pair with 'INTEGRA' label
Rear - 1 pair PLAIN**HARDWARE KIT CONTENTS**

ITEM NO.	DESCRIPTION	QTY	ITEM NO.	DESCRIPTION	QTY
1	M8 Flange Nut	7	6	M8 Rubber Washer	4
2	Tech screw 14-20x22 SDS	5	7	5/16 x 7/8 x 18g F/Washer	6
3	M8 x 35 Rail Bolt (3mm plate)	1	8	M8 x 25 Rail Bolt (5mm plate)	2
4	M8 x 11mm Flange Bolt	12	9	M8 Wired Bolt	4
5	8Gx12mm truss hd sds	16	10	Rust Inhibitor	1

STEPBOARD BRACKETS

PART NO.	DESCRIPTION	QTY
9AN045	Front & Centre Common	4
9AN046	Rear Common	2

BEFORE INSTALLATION: PLEASE READ THESE INSTRUCTIONS CAREFULLY BEFORE INSTALLATION, PAYING SPECIAL ATTENTION TO ALL 'NOTES'. FAILURE TO DO SO MAY RESULT IN DAMAGE OF PARTS AND/OR INJURY TO INSTALLER OR CUSTOMER.**TOOLS REQUIRED:** • ELECTRIC DRILL OR EQUIV. • NO. 2 PHILLIPS TIP INSERT BIT • TAPE MEASURE • 10 & 13MM SOCKET & RATCHET • 13MM RING/OPEN SPANNER • TORQUE WRENCH • 9MM DRILL BIT**FITTING PROCEDURE****NOTE:** The INTEGRA STEPBOARDS have been assembled with the hex nuts already inserted into the board channels for your convenience. For now, lay them in a safe place to prevent damage and fit the brackets as per instructions below.**1. Move to the R/H (Driver's side) of the vehicle and proceed as follows.**

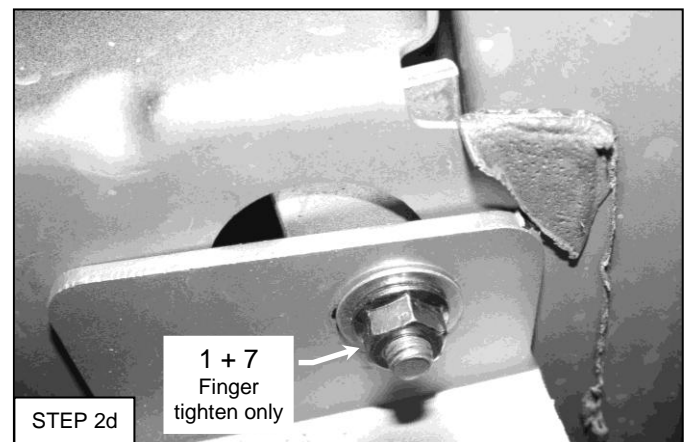
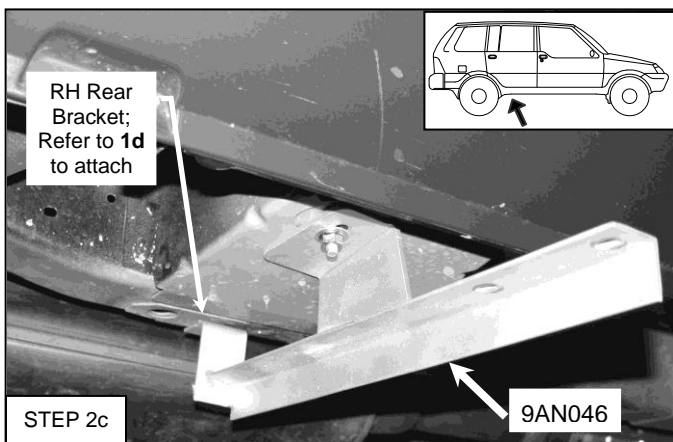
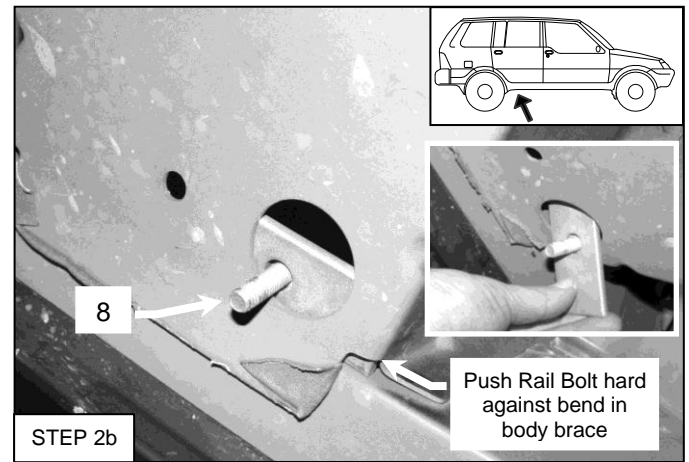
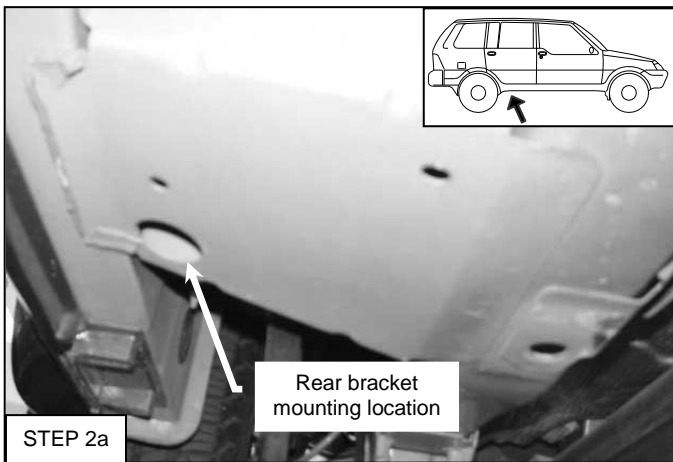
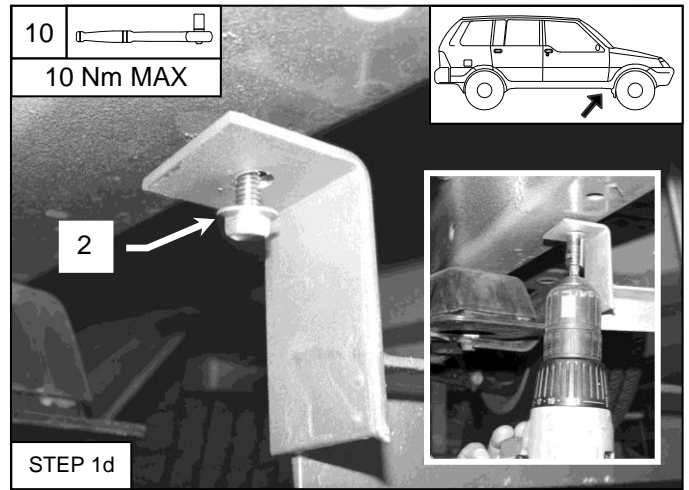
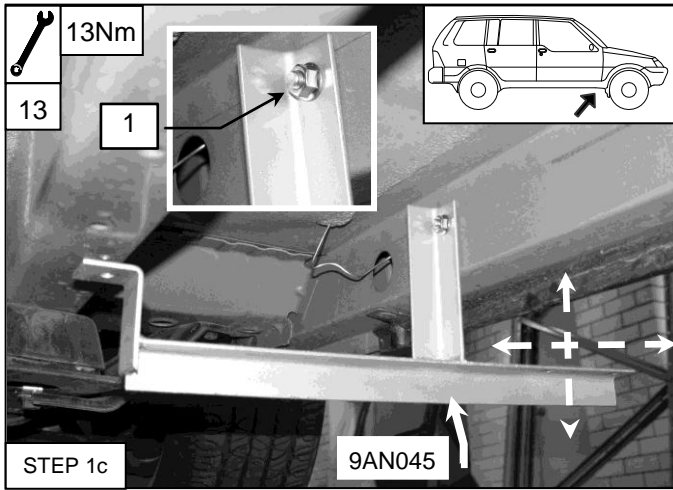

Step 2e: Place step board on brackets and move RH rear bracket so step is parallel to sill. Repeat step 1d to attach back part of Rear RH bracket.

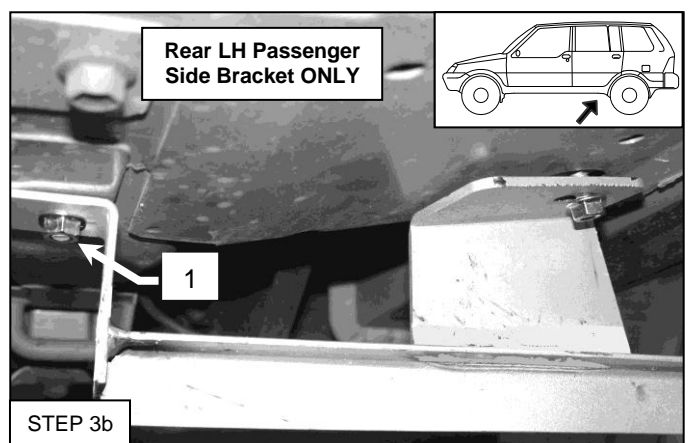
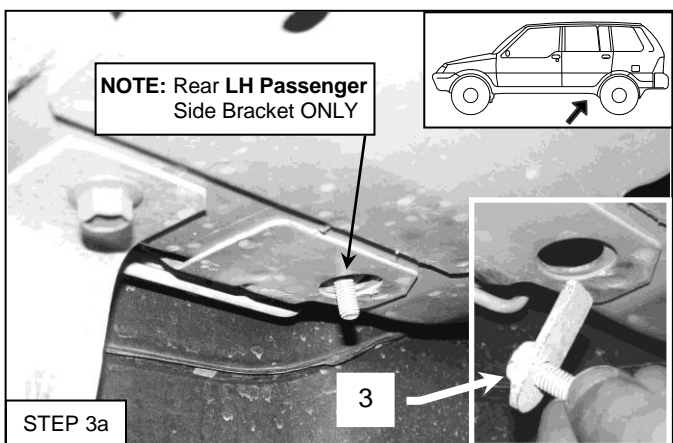

Step 4: With stepboard still on brackets, position centre bracket 900mm from front mudflap. Ensure step is parallel to sill. **Mark hole with centre punch and drill Ø9mm hole. Apply Kingsley Rust inhibitor to raw metal edges (Item 10). Repeat steps 1b to 1d to attach bracket.**

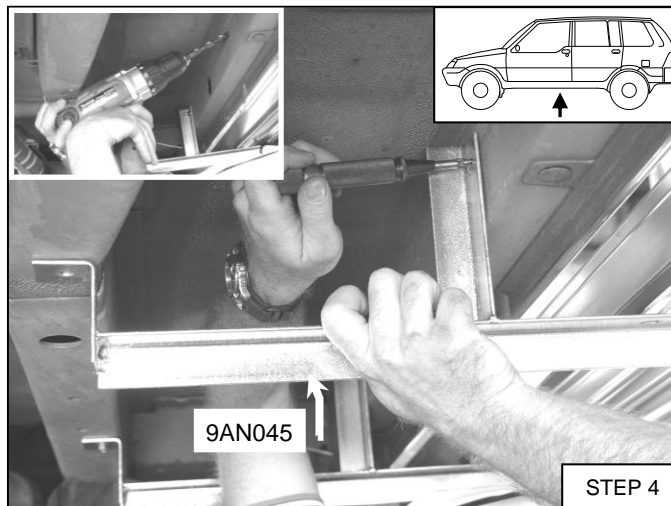

5. **Optional:** You can now sit and mark the position of the step pads on the side step. Note: Location of step pads is at the discretion of the customer – As a guide fit the step pads under door centres.

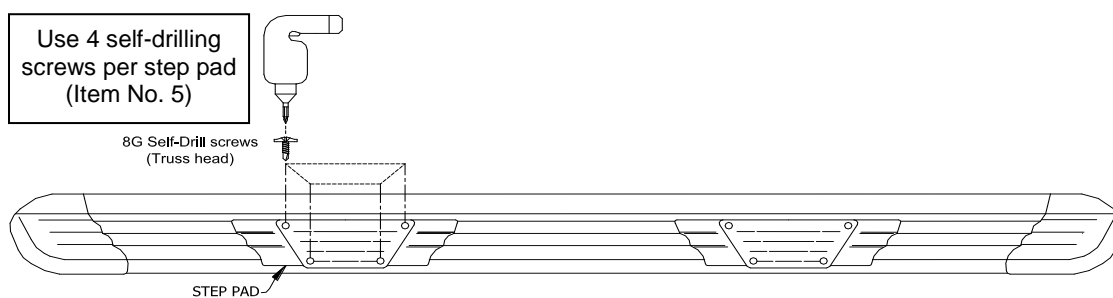

STEP 5

6. Lift the Side Step back onto the brackets and position in the centre of the wheel arches. Secure the side step to the brackets using 2x M8x11mm flange bolts per bracket picking up nuts in the channels of the Side Step. Fingers tighten only.

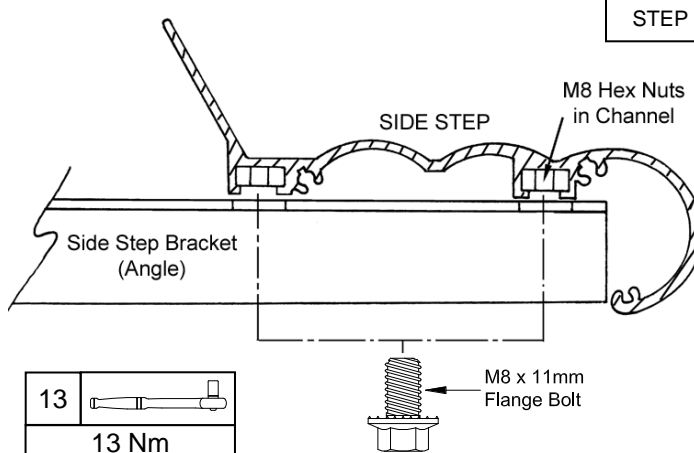

STEP 6

7. Check that the Side Step is pushed in and parallel to the sill. Finally tighten all nuts and bolts before using the Side Step. Recommended max torque:

8. Replace Rubber bung for the front bracket

- M8 Bolts = 13Nm (10 ft.lb).
- Tech Screw = 10Nm (7 Ft.lb).

9. Repeat steps 1 ~ 8 for the L/H (Passengers) side of the vehicle.

- **Place “KINGSLEY SIDE STEP Warranty” on customers front seat**
 - **Clean the side steps if necessary using PH - Neutral soapy water**
- Your Integra Steps are now ready for use***

In accordance with our policy of total quality commitment and customer service, we invite you to contact us on our toll free hotline should you have any questions

Telephone: (02) 9792 2566 or Toll Free 1800 654 767

Kingsley Enterprises Pty Ltd 123 Eldridge Road Bankstown NSW 2200 Australia