

Kingsley

STEPBOARDS®

Part No: 18M62D

**MITSUBISHI TRITON D/C GLX 2/4WD
12/1999 - Current
Component List**

Board Length: 1860mm

End Caps: Front - 1 pair Upswept
Rear - 1 pair Upswept

HARDWARE KIT CONTENTS

PART NO.	DESCRIPTION	QTY
91Z001	M8x20mm Hex Bolt	12
91Z003	M8x14mm Bolt	20
91Z017	M8 Flange Nut	20
91Z018	M8 Hex Nut	12

PART NO.	DESCRIPTION	QTY
91Z023	M8 Flat Washer	12
91Z105	M8 Lock Washer	12
97Z900	Rust Inhibiter Sachet	1

BRACKETS AND ANGLES

PART NO.	DESCRIPTION	QTY
9AM015	FRONT BKT	2
9AM015	CENTRE BKT	2
9AM022	REAR BKT	2

**Check kit supplied is for the vehicle being fitted and is complete as listed.
Read the instructions to be sure you understand all aspects of fitting the vehicle before
proceeding.**

TOOLS REQUIRED:

*ELECTRIC DRILL OR EQUIVALENT *3 & 8MM DRILL BIT
*SOCKET SET TO 13MM WITH RATCHET *MARKING PEN *CENTRE PUNCH *HAMMER

FITTING INSTRUCTIONS:

1. Assemble the two stepboards by fitting to one end of each stepboard an upswept end cap with M8x14mm Bolts and Flange Nuts. **See Figure 1**
Slide into the underside channels of the boards, three M8 Hex Nuts. (6 per board)
Attach the remaining Upswept end caps to the boards as described above.
2. Move to under side of vehicle and using figure 2 mark the body stiffeners to which the brackets will attach both sides. Hold the bracket hard up to floor and in against back of sill, mark holes from bracket to body brace, three (3) each side. Note: rear brackets different to front and centre brackets. Make sure brackets are level before marking for drilling.
NOTE: The brackets are identified with stamped part numbers. See TABLE "BRACKETS & ANGLES"
3. Drill each marked hole to 8mm diameter to allow fitting of brackets. rust proof all raw metal left by drilling.
❖ **NOTE: It has been found on some vehicles that the body stiffening brackets to which the Stepboard brackets attach have a bent section which will interfere with the bracket attachment. This will need straightening before drilling for bracket attachment.**
4. Attach brackets to drilled and proofed holes using M8 x 20mm bolts and M8 flange nuts. Tighten fully.
5. Lift the assembled boards onto the fitted brackets and attach using M8x14mm Bolts, Flat and Lock washers, picking up nuts in the underside channels of the board. **See Figure 3.**
6. Ensure stepboards are parrallel to sill and level. Tighten all nuts and bolts before using the stepboards. Clean stepboards if necessary using **soapy water only.**

Part No: 18M62D

**MITSUBISHI TRITON D/C GLX 2/4WD
12/1999 - Current
Component List**

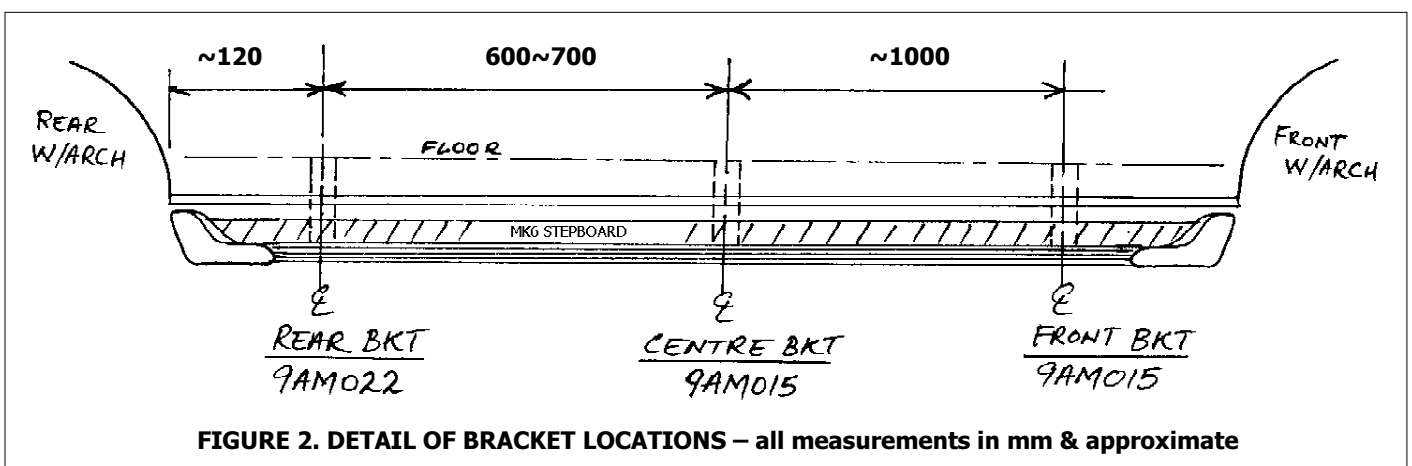
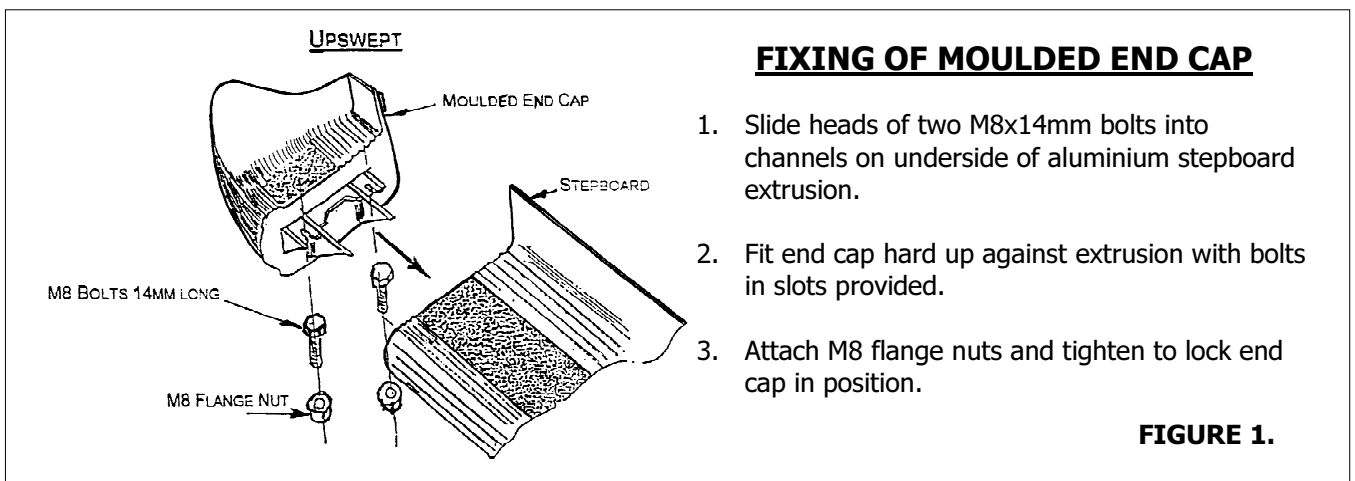

Kingsley

STEPBOARDS®

Part No: 18M62D

**mitsubishi Triton D/C GLX 2/4WD
12/1999 - Current
Component List**

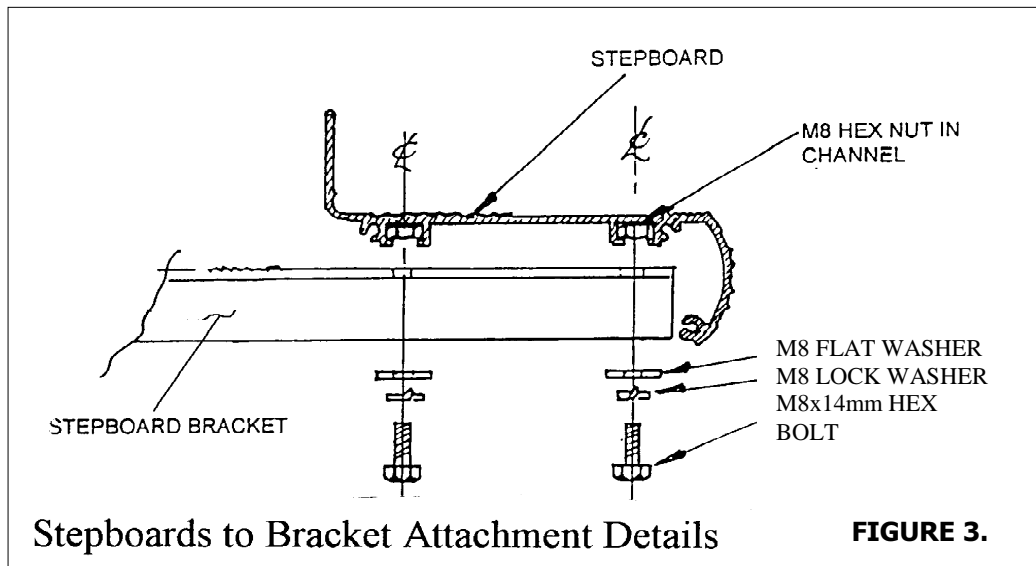

Your Stepboards are now ready for use

In accordance with our policy of total quality commitment and customer service, we invite you to contact us on our toll free hotline should you have any questions

Telephone: (02) 9792 2566 or Toll Free 1800 654 767

Kingsley Enterprises Pty Ltd 123 Eldridge Road Bankstown NSW 2200 Australia