

# Kingsley

# STEPBOARDS®

## FITTING INSTRUCTIONS

**Part No: 18T93D**  
**TOYOTA HILUX DUAL CAB 8GEN**  
**Commencing 10/2015**



### Kit Contents (Approximate Fitting Time: 70 minutes)

<p>1 Part Number 2x 9AL125 Front Brackets</p>	<p>2 Part Number 2x 9AL126 Centre Brackets</p>	<p>3 Part Number 2x 9AL127 Rear Brackets</p>	<p>4 12x M8x25mm Hex Bolt (See note below)</p>	<p>5 24x M8 Spring Washers</p>	<p>6 12x M8 Flat Washer</p>
<p>7 2x M8 Flange Nut (Non-Serrated)</p>	<p>8 12x M8x20mm Hex Bolt</p>	<p>9 12x M8 Flat Washer (4mm thick)</p>	<p>10 8x M8x14mm Bolt</p>	<p>11 8x M8 Flange Nut (Serrated)</p>	<p>12 12x M8 Hex Nut</p>
<p>13 1x Bullnose Endcap Left Hand Front</p>	<p>14 1x Bullnose Endcap Right Hand Front</p>	<p>15 1x Upswept Endcap Left Hand Rear</p>	<p>16 1x Upswept Endcap Right Hand Rear</p>	<p>17 2x Stepboards</p>	<p>18 2x Plastic Capping</p>

**\*Note: Only 10 of Item 4 are used in this kit. Discard the extra 2 bolts.**

**TOOLS REQUIRED:** • Tape Measure • 13mm Sockets / Spanners • Torque Wrench

**BEFORE INSTALLATION:** Please read these instructions carefully before installation, paying special attention to all 'Notes'. Failure to do so may result in damage of parts and/or injury to the installer or customer. Place side steps in a safe place until required. Check the contents of this kit before commencing fitment & report any discrepancies.

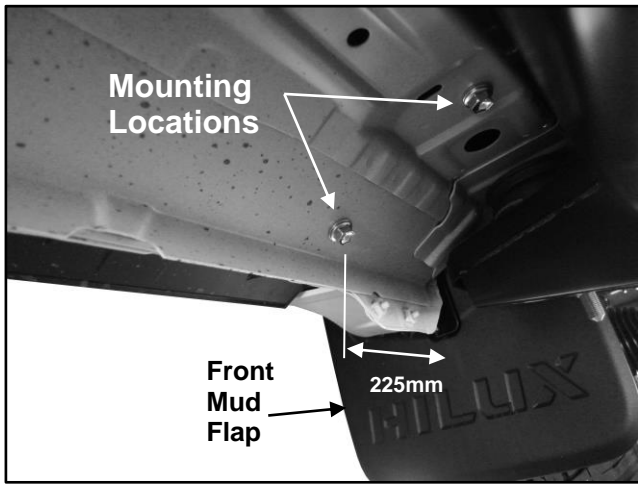

**Step 1. Move to the L/H (Passenger's) side of the vehicle.**

Locate the 2 x M8 bolts at the front bracket mounting position, approximately 225mm from the front mud flap.

Remove the factory fitted bolts and discard.

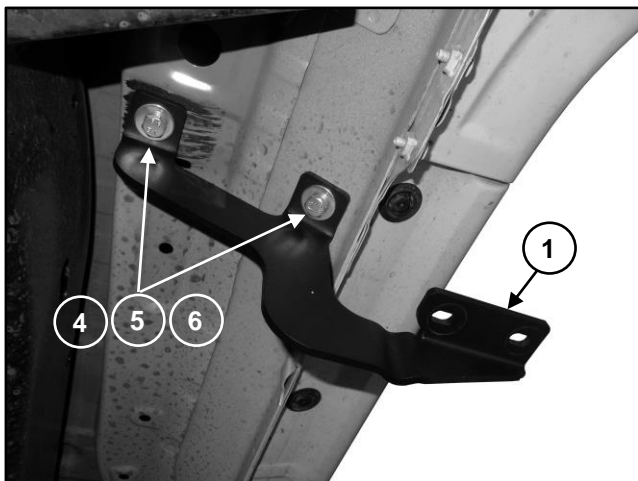

**Step 2. Attach the Front Bracket [Item 1] to the front mounting location using:**  
 2 x M8x25mm Hex Bolts [Item 4]  
 2 x M8 Spring Washers [Item 5]  
 2 x M8 Flat Washers [Item 6]

Ensure the bracket is level and square, then finger tighten only.

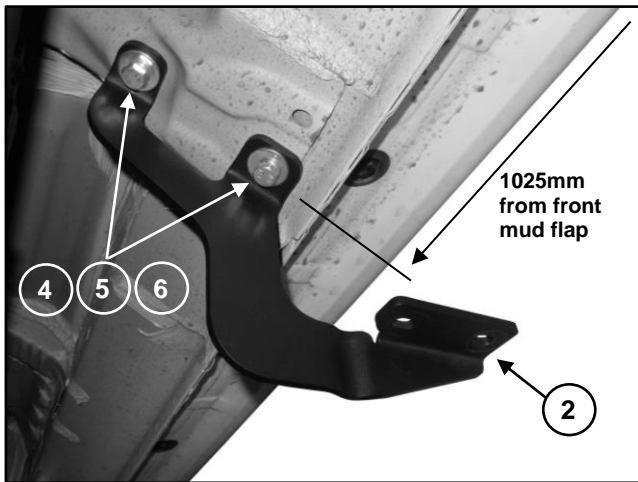

**Step 3. Move to the centre of the cab.**

Locate the 2 x M8 bolts at the centre bracket mounting position, approximately 1025mm from the front mud flap.

Remove the factory fitted bolts and discard.

Repeat **Step 2** to attach the Centre Bracket [Item 2] to this mounting location.

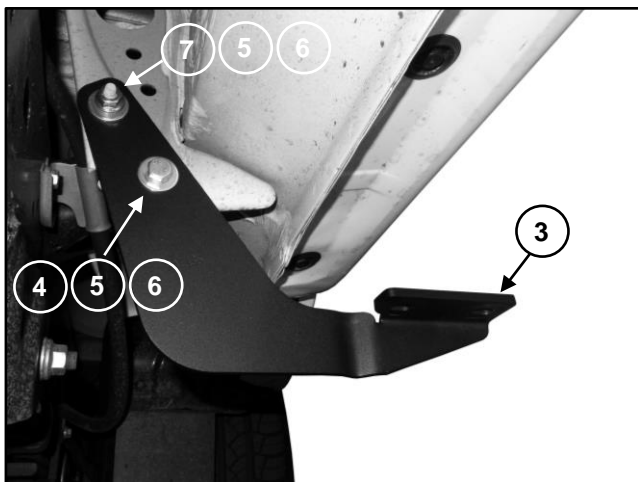

**Step 4. Move to the rear of the cab.**

Locate the M8 stud and captive nut at the rear bracket mounting position, approximately 260mm from the rear of the cab.

Attach the Rear Bracket [Item 3] to the rear mounting location using:

- 1 x M8x25mm Hex Bolts [Item 4]
- 2 x M8 Spring Washers [Item 5]
- 2 x M8 Flat Washers [Item 6]
- 1 x M8 Flange Nut (Non-Serrated) [Item 7]

Ensure the bracket is level and square, then finger tighten only.

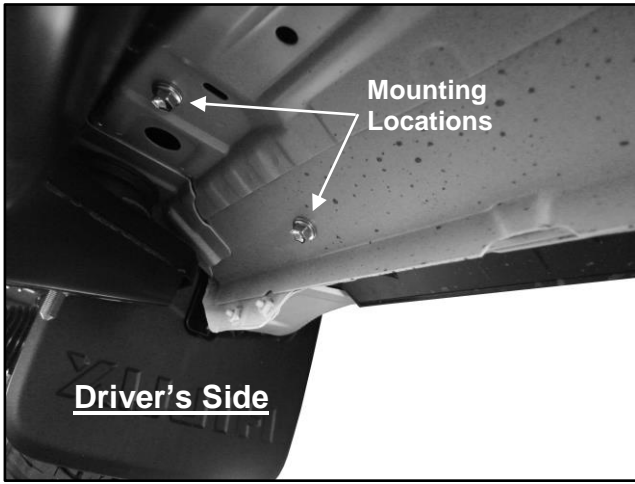

**Step 5. Repeat Steps 1 – 4 to fit the remaining brackets to the R/H (Driver's) side of the vehicle.**

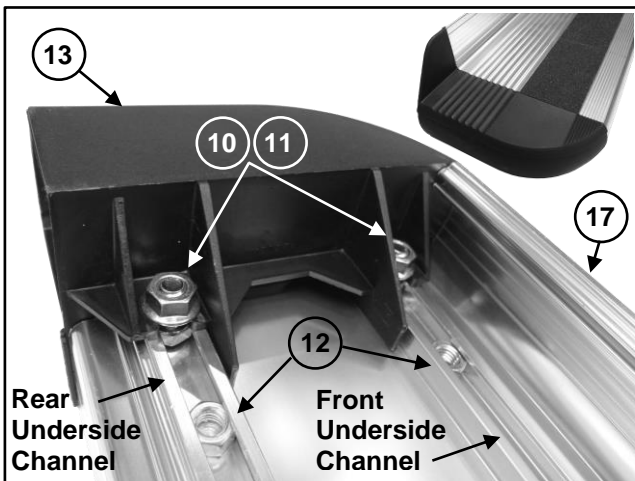

**Step 6. Stepboard Assembly:**

- a. Slide 1 x M8x14mm Hex Bolt [Item 10] into each underside channel of a Stepboard [Item 17], then fit and secure 1 x Front End Cap [Item 13] using 2 x M8 Flange Nuts [Item 11].
- b. Slide 3 x M8 Hex Nuts [Item 12] into each underside channel of the Stepboard, totalling six (6) Hex Nuts per Stepboard.
- c. Complete the Stepboard Assembly by attaching 1 x Rear End Cap [Item 15] as outlined in a. above.

*Repeat for the remaining Stepboard.*

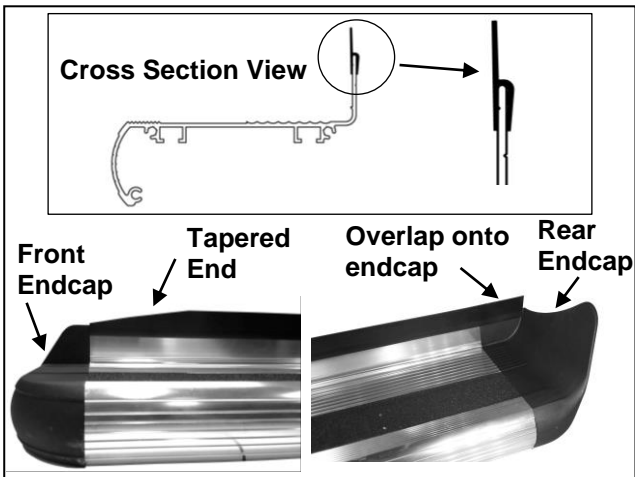

**Step 7.** Attach the plastic capping [Item 18] onto the back leg of the Stepboard [Item 17] by gradually pushing the capping firmly down along the whole length.

Ensure the tapered end is located at the front of each Stepboard, starting at the alloy extrusion and overlapping onto the endcap at the rear of the board.

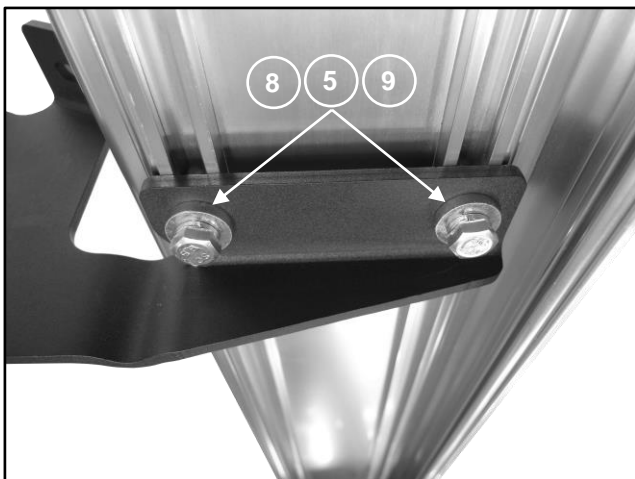

**Step 8.** Install Stepboards to both sides of vehicle using the following quantity of fasteners for each bracket:

- 2 x M8x20mm Hex Bolts [Item 8]
- 2 x M8 Spring Washers [Item 5]
- 2 x M8 Flat Washers (4mm thick) [Item 9]

Position Stepboards 5-10 mm behind front mud flaps.

**Tighten all M8 fasteners to 13 Nm.**

- Place “KINGSLEY SIDE STEP Warranty” on customer’s front seat
- Clean the Side Steps if necessary using PH - Neutral soapy water ONLY

**Your Stepboards are now ready for use**