

KINGSLEY***INTEGRA STEP***[®]**PART No: 30T240**

**TOYOTA LANDCRUISER - PRADO
1996 - CURRENT
COMPONENT LIST**

ENDCAPS: FRONT STANDARD - FITTED**REAR STANDARD - FITTED****HARDWARE KIT CONTENTS**

PART NO.	DESCRIPTION	QTY
91Z001	M8X20MM BOLT	10
91Z017	M8 FLANGE NUT	10
91Z003	M8X14MM BOLT	12

PART NO.	DESCRIPTION	QTY
91Z105	M8 LOCK WASHER	14
91Z104	8GX12MM TRUSS HD SDS	16
91Z023	M8 FLAT WASHER	12

BRACKETS AND ANGLES

PART NO.	DESCRIPTION	QTY
9AL040	L/H FRONT BRACKET	1
9AL041	R/H FRONT BRACKET	1
9AL042	CENTRE BRACKET	2
9AL043	REAR BRACKET	2



CHECK KIT SUPPLIED IS FOR THE VEHICLE BEING FITTED AND IS COMPLETE AS LISTED.

READ THE INSTRUCTIONS TO BE SURE YOU UNDERSTAND ALL ASPECTS OF FITTING THE VEHICLE BEFORE PROCEEDING.

TOOLS REQUIRED: * SOCKET SET TO 13MM WITH RATCHET * 13MM SPANNER

FITTING INSTRUCTIONS:

1. THE TWO INTEGRA BOARDS HAVE BEEN ASSEMBLED WITH THE HEX NUTS ALREADY INSERTED INTO THE UNDERSIDE BOARD CHANNELS FOR YOUR CONVENIENCE, FOR NOW, LAY THEM ASIDE AND FIT BRACKETS AS PER INSTRUCTIONS BELOW.
2. MOVE TO THE UNDERSIDE OF THE VEHICLE AND ATTACH THE THREE STEPBOARD BRACKETS FRONT CENTRE AND REAR ON EACH SIDE. THE FRONT BRACKETS FIT ON A CAPTIVE STUD AND ARE SECURED WITH AN M8 FLANGE NUT AND M8 X 20MM BOLT AND LOCK WASHER INTO A CAPTIVE NUT. THE CENTRE AND REAR BRACKETS ARE SECURED WITH M8 X 20MM BOLTS AND FLANGE NUTS TO EXISTING HOLES IN BODY BRACES.
3. **OPTIONAL:** YOU CAN NOW FIT THE ADDITIONAL STEP PADS TO YOUR BOARDS AS REQUIRED USING SELF DRILLING SCREWS PROVIDED IN KIT. SEE FIGURE 2. NOTE: LOCATION OF STEP PADS ARE AT THE DISCRETION OF THE FITTER/CUSTOMER – AS A GUIDE FIT THE STEP PADS WITH INTEGRA LABEL UNDER FRONT DOOR CENTRES AND STEP PADS WITHOUT INTEGRA LABEL UNDER REAR DOOR CENTRES.
4. ATTACH INTEGRA BOARD TO BRACKETS WITH M8 X 14MM BOLTS, LOCK WASHERS AND FLAT WASHERS, PICKING UP NUTS IN THE CHANNELS ON THE UNDERSIDE OF THE STEPS. SEE FIGURE 1.
5. TIGHTEN ALL NUTS AND BOLTS BEFORE USING THE INTEGRA STEPS. CLEAN INTEGRA STEPS IF NECESSARY USING **SOAPY WATER ONLY.**

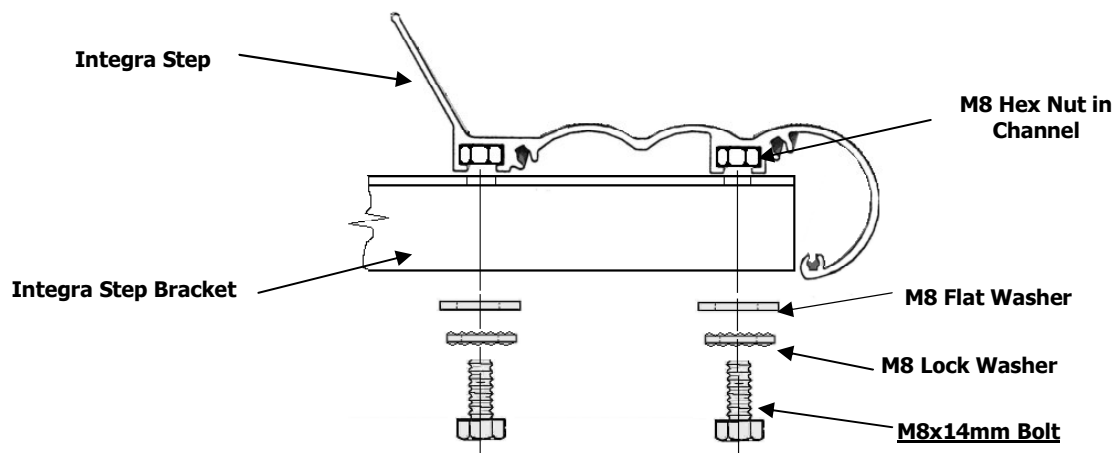
PART No: 30T240**TOYOTA LANDCRUISER - PRADO
1996 - CURRENT
COMPONENT LIST****ATTACHMENT OF INTEGRA STEP TO BRACKET**

IMPORTANT: YOU MUST USE M8x14MM HEX BOLTS (YELLOW) AND M8 FLAT AND LOCK WASHERS UNDER HEAD OF BOLTS TO AVOID DAMAGE TO INTEGRA STEP.

FIGURE 1.

ATTACHMENT OF STEP-PADS TO INTEGRA STEP

FIGURE 2.

YOUR INTEGRA STEPS ARE NOW READY FOR USE

IN ACCORDANCE WITH OUR POLICY OF TOTAL QUALITY COMMITMENT AND CUSTOMER SERVICE, WE INVITE YOU TO CONTACT US ON OUR

TOLL FREE HOTLINE SHOULD YOU HAVE ANY QUESTIONS

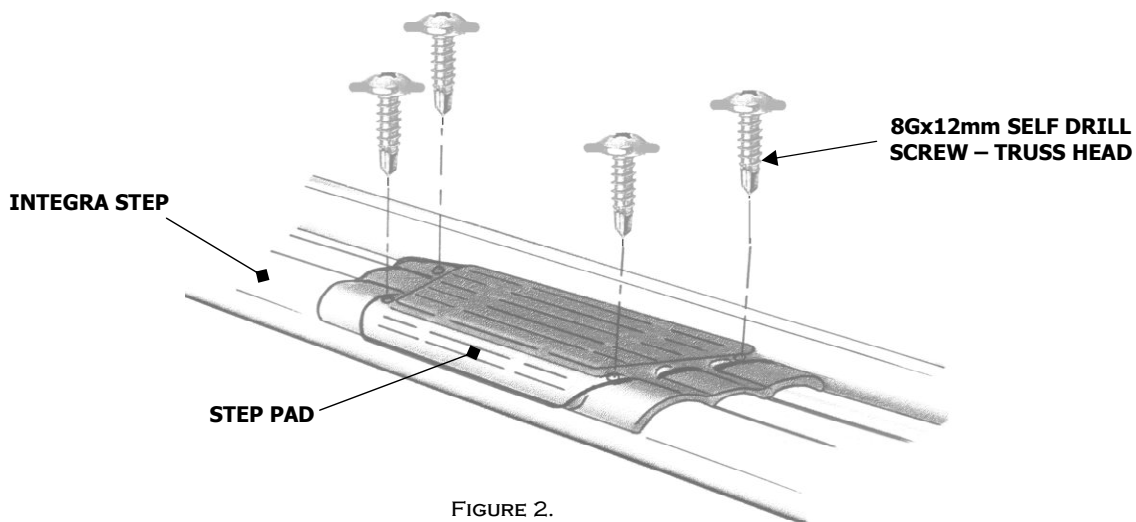
TELEPHONE: (02) 9792 2566 OR TOLL FREE 1800 654 767

KINGSLEY ENTERPRISES PTY LTD 123 ELDRIDGE ROAD BANKSTOWN NSW 2200 AUSTRALIA