

Kingsley

STEPBOARDS®

Part No: 18R910

**RANGE ROVER DISCOVERY 4 DOOR
3/1991 - Current
Component List**

Board Length: 1570mm

End Caps: Front - 1 pair Mudflap
Rear - 1 pair Bullnose

HARDWARE KIT CONTENTS

PART NO.	DESCRIPTION	QTY
91Z003	M8x14mm Bolt	16
91Z017	M8 Flange Nut	4
91Z018	M8 Hex Nut	12
91Z023	M8 Flat Washer	12
91Z105	M8 Lock Washer	12
91Z110	Coach Screw	6

PART NO.	DESCRIPTION	QTY
91Z013	M6x20mm H/T Bolt	6
91Z024.	M6 Flat Washer	12
91Z022	M6 Flange Nut	6
91Z035	Tech Screw	6
92Z007	200mm Clean Seal Foam Rubber	2
97Z900	Rust Inhibiter Sachet	1

BRACKETS AND ANGLES

PART NO.	DESCRIPTION	QTY
9AW025	FRONT BKT	2
9AW026	CENTRE BKT	2
9AW027	REAR BKT	2

**Check kit supplied is for the vehicle being fitted and is complete as listed.
Read the instructions to be sure you understand all aspects of fitting the vehicle before
proceeding.**

TOOLS REQUIRED:

*ELECTRIC DRILL OR EQUIVALENT * 6.5MM DRILL BIT
*SOCKET SET TO 13MM WITH RATCHET *MARKING PEN
* 10MM SPANNER

FITTING INSTRUCTIONS:

1. Assemble the two stepboards by fitting to the front end of each stepboard a curved mud flap with coach screws and washers. Slide into the underside channels of the boards, three M8 Hex Nuts. (6 per board)
Attach the Bull Nose end caps to the rear of the boards with M8x14mm Bolts and Flange Nuts. **See Figure 1**

2. **Starting on either side of vehicle proceed as follows:** Mark the positions where the brackets are to be attached. See figure 2. NOTE: REMOVE BOTH FRONT OE MUDFLAPS IF THEY ARE FITTED TO YOUR VEHICLE.

IMPORTANT: THE FRONT, CENTRE AND REAR BRACKETS VARY IN HEIGHT. THE CORRECT BRACKET MUST BE ATTACHED AT THE POSITION SHOWN IN FIGURE 2.

NOTE: The brackets are identified with stamped part numbers.(See TABLE "BRACKETS & ANGLES)

3. The brackets are to be placed on the inside of the vehicle sill – verticle leg hard up to floor.
4. Mark the lower hole in upright leg of brackets on the vehicle sill and drill to match with 6.5mm drill. See figure 3. Rust proof raw metal. NOTE: IF VEHICLE IS FITTED WITH SELF LEVELLING REAR AIR SUSPENSION – YOU MAY NEED TO REMOVE PLASTIC SILL COVER TO DRILL HOLE IN SILL FOR CENTRE BRACKET (PASS. SIDE)
5. Attach brackets with M6x20mm bolt, flat washer, under head of bolt from outside sill flange nut behind bracket on inside of sill. With bracket now in position, fix the TEC screw through top hole in bracket behind sill. This will now stabilise the bracket. See figure 3.
6. Now, clean inside edge of front wheel arches and stick the rubber seal as shown in Figure 4.

Part No: 18R910

**RANGE ROVER DISCOVERY 4 DOOR
3/1991 - Current
Component List**

7. Lift the assembled boards onto the fitted brackets and attach using M8x14mm Bolts, Flat and Lock washers, picking up nuts in the underside channels of the board. See figure 5.
8. Ensure stepboards are parallel to sill and level. Check Mudflaps are hard back in front wheel arch and tighten all nuts and bolts before using the stepboards. Clean stepboards if necessary using **soapy water only**.

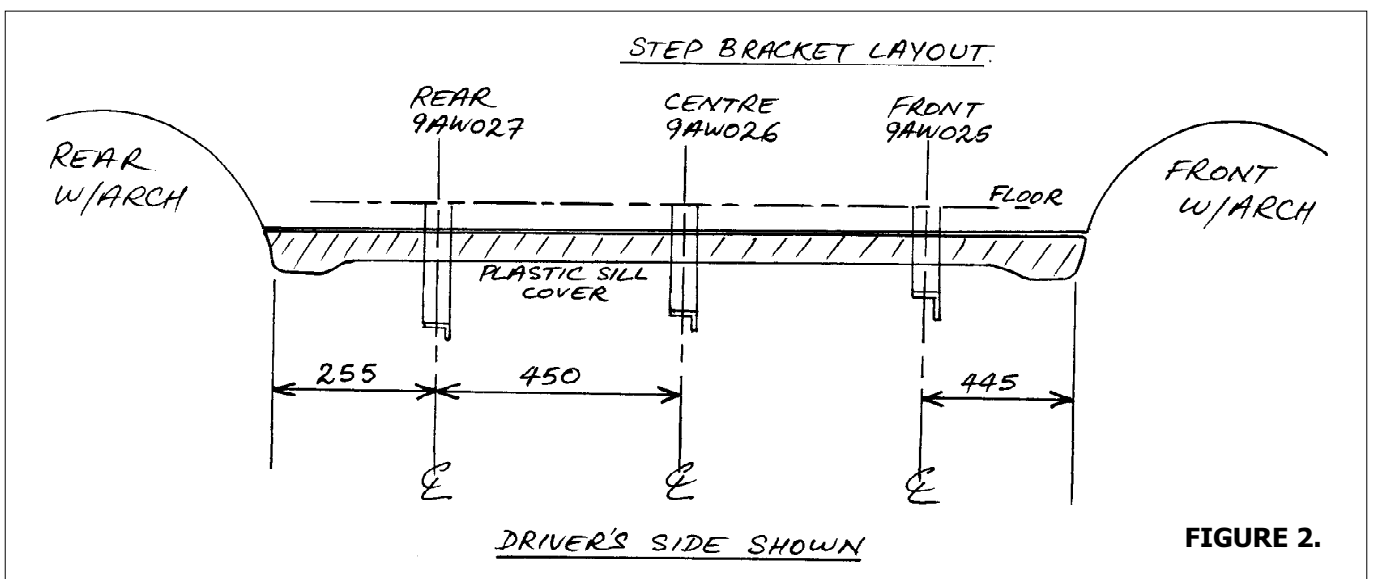
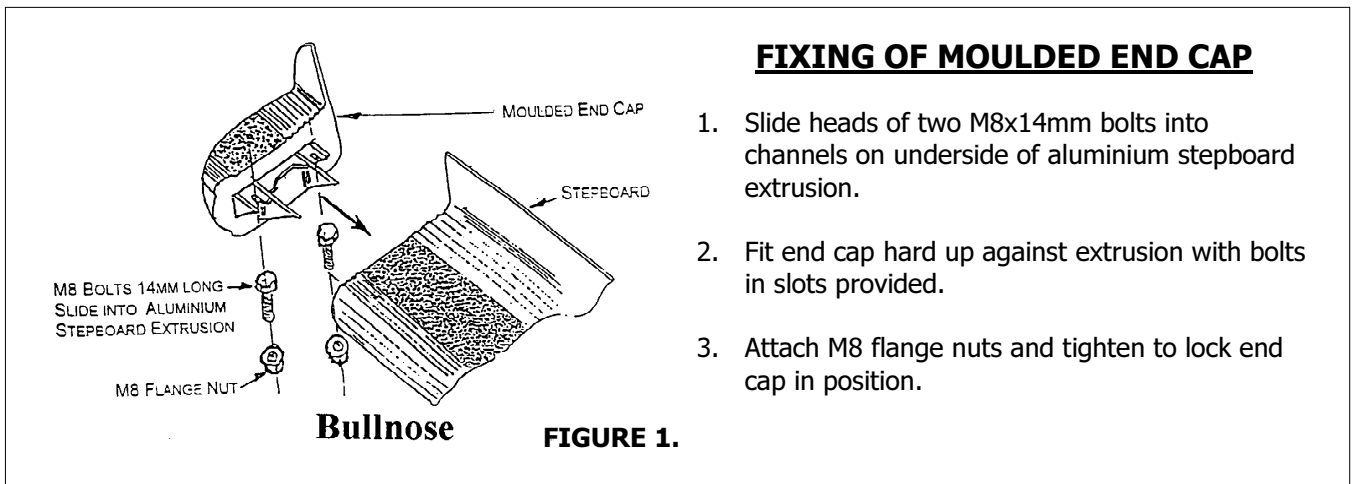

Kingsley

STEPBOARDS®

Part No: 18R910

**RANGE ROVER DISCOVERY 4 DOOR
3/1991 - Current
Component List**

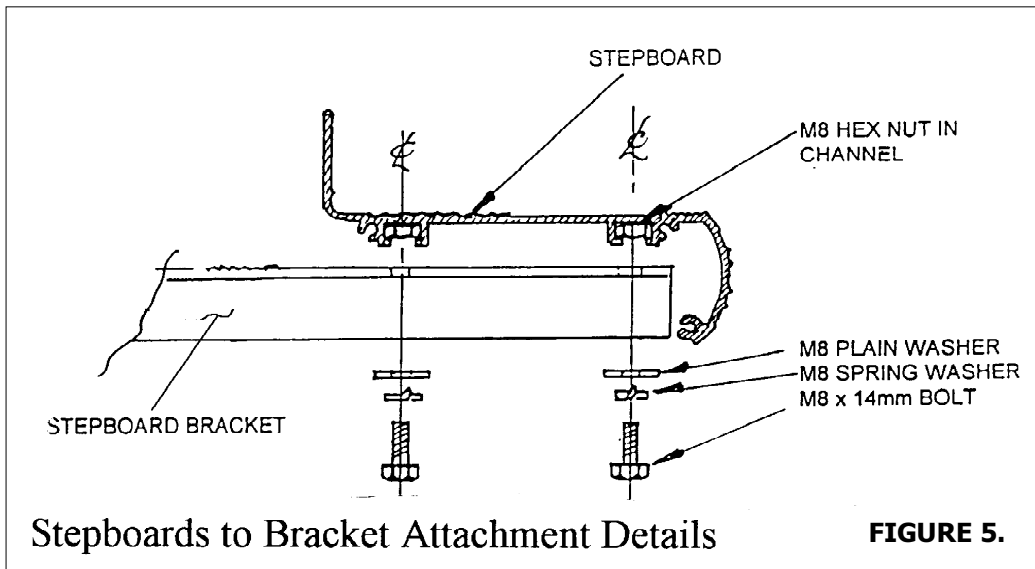
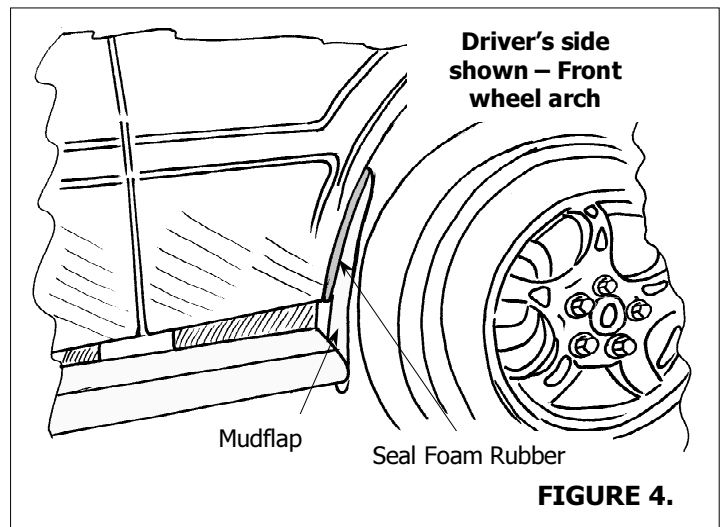
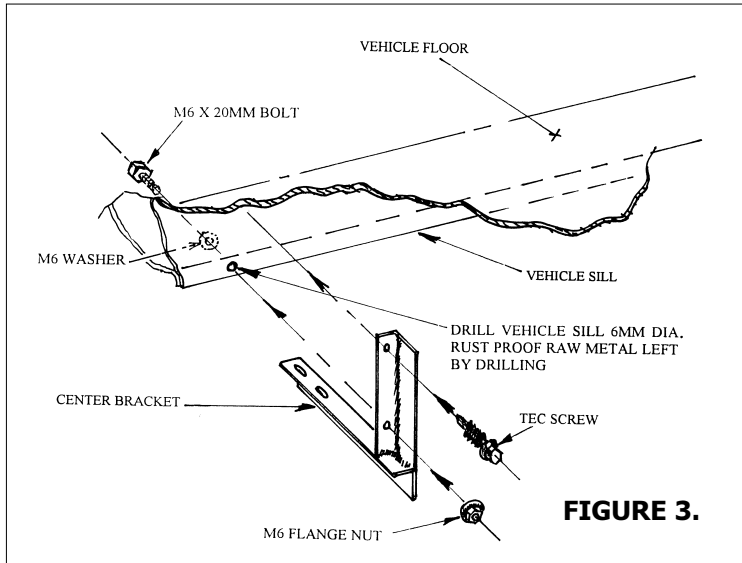

Stepboards to Bracket Attachment Details

Your Stepboards are now ready for use

In accordance with our policy of total quality commitment and customer service, we invite you to contact us on our toll free hotline should you have any questions

Telephone: (02) 9792 2566 or Toll Free 1800 654 767

Kingsley Enterprises Pty Ltd 123 Eldridge Road Bankstown NSW 2200 Australia